

Installation Manual Stabilized FISH SIZE INDICATOR

Model **FCV-38**

(Product Name: FISH FINDER)

SAFETY INSTRUCTIONS	i
SYSTEM CONFIGURATIONS	iii
EQUIPMENT LISTS	iv
1. MOUNTING.....	1-1
1.1 Processor Unit	1-1
1.2 Transceiver Unit.....	1-3
1.3 Trackball Control Unit	1-4
1.4 Transducer.....	1-7
1.5 Junction Box (Option)	1-10
1.6 DVI/USB Repeater (Option).....	1-10
2. WIRING.....	2-1
2.1 Processor unit.....	2-2
2.2 Transceiver Unit.....	2-6
2.3 Trackball Control Unit	2-8
2.4 Transducer.....	2-10
2.5 Junction Box (option)	2-11
2.6 DVI/USB Repeater (Option).....	2-13
2.7 Input/Output Sentences (NMEA0183)	2-14
3. INITIAL SETTINGS.....	3-1
3.1 How to Set the Language and Measurement Unit	3-1
3.2 How to Set the [Service] Menu	3-2
3.3 Communication Port Setting	3-7
3.4 External Echo Sounder Setting.....	3-10
3.5 Calibration Setting.....	3-12
3.6 Stabilization Setting	3-16
3.7 How to Take a Still Image of the RX Monitor	3-19
3.8 Reset to Default Setting	3-19
3.9 Retrofit from FCV-30.....	3-20
APPENDIX 1 JIS CABLE GUIDE	AP-1
PACKING LISTS	A-1
OUTLINE DRAWINGS	D-1
INTERCONNECTION DIAGRAMS.....	S-1



FURUNO ELECTRIC CO., LTD.

www.furuno.com

All brand and product names are trademarks, registered trademarks or service marks of their respective holders.

ECF

(Elemental Chlorine Free)

The paper used in this manual
is elemental chlorine free.

FURUNO ELECTRIC CO., LTD.

9-52 Ashihara-cho,
Nishinomiya, 662-8580, JAPAN

• FURUNO Authorized Distributor/Dealer

All rights reserved. Printed in Japan

A : SEP. 2020

Pub. No. IME-23920-A

(AKMU) FCV-38





00019701510













SAFETY INSTRUCTIONS

The installer must read the applicable safety instructions before attempting to operate or install the equipment.

 WARNING	Indicates a potentially hazardous situation which, if not avoided, could result in death or serious injury.
 CAUTION	Indicates a potentially hazardous situation which, if not avoided, can result in minor or moderate injury.

 Warning, Caution	 Prohibitive Action	 Mandatory Action
--	--	--

 WARNING
 ELECTRICAL SHOCK HAZARD Do not open the equipment unless totally familiar with electrical circuits and service manual. Only qualified personnel are allowed to work inside the equipment.
 Turn off the power at the mains switchboard before beginning the installation. Fire, electrical shock or serious injury can result if the power is left on or is applied while the equipment is being installed.
 Install the transducer according to the installation instructions. Failure to install the transducer correctly may result in water leakage and damage to the ship's hull.
 Be sure no water leaks in at the transducer mounting location. Water leakage can sink the vessel. Also, confirm that the transducer will not be loosened by ship vibrations. The installer of the equipment is solely responsible for the proper installation of the equipment. FURUNO will assume no responsibility for any damage associated with improper installation.
 For wooden or FRP vessel using a steel tank, attach a zinc plate to the hull to prevent electrolytic corrosion. Electrolytic corrosion can, in the worst case, result in loss of the transducer.

 CAUTION																		
 Ground the equipment to prevent electrical shock and mutual interference.																		
 Do not transmit with the transducer out of water. The transducer may become damaged.																		
 Use the proper cable and fuse. Use of an incorrect cable and fuse can damage the equipment and cause fire.																		
 Observe the following safe compass distances to prevent interference to a magnetic compass:																		
<table border="1"> <thead> <tr> <th></th> <th>Standard compass</th> <th>Steering compass</th> </tr> </thead> <tbody> <tr> <td>Processor Unit (CV-380)</td> <td>2.15 m</td> <td>1.35 m</td> </tr> <tr> <td>Transceiver Unit (CV-382)</td> <td>2.15 m</td> <td>1.35 m</td> </tr> <tr> <td>Trackball Control Unit (RCU-026)</td> <td>0.30 m</td> <td>0.30 m</td> </tr> <tr> <td>Junction Box (CV-304)</td> <td>1.10 m</td> <td>0.70 m</td> </tr> <tr> <td>DVI/USB Repeater (TM000-FDX06)</td> <td>0.35 m</td> <td>0.30 m</td> </tr> </tbody> </table>		Standard compass	Steering compass	Processor Unit (CV-380)	2.15 m	1.35 m	Transceiver Unit (CV-382)	2.15 m	1.35 m	Trackball Control Unit (RCU-026)	0.30 m	0.30 m	Junction Box (CV-304)	1.10 m	0.70 m	DVI/USB Repeater (TM000-FDX06)	0.35 m	0.30 m
	Standard compass	Steering compass																
Processor Unit (CV-380)	2.15 m	1.35 m																
Transceiver Unit (CV-382)	2.15 m	1.35 m																
Trackball Control Unit (RCU-026)	0.30 m	0.30 m																
Junction Box (CV-304)	1.10 m	0.70 m																
DVI/USB Repeater (TM000-FDX06)	0.35 m	0.30 m																



CAUTION



The transducer cable must be handled carefully, following the guidelines below.

- Keep the cable away from oil and fuels.
- Keep the cable away from locations where it may be damaged during the installation.
- Do not carry the transducer using only the cable. The cable may become damaged or disconnected.
- Do not shorten the transducer cable.
- Do not paint the cable.

The cable sheath is made of chloroprene or vinyl chloride, which are easily damaged by plastic solvents such as toluene. Locate the cables away from plastic solvents.



Do not allow warm water or any other liquid other than seawater or freshwater to contact the transducer.

Damage to the transducer may result.



Do not install the transducer where noise or air bubbles is present.

Performance will be affected.

SYSTEM CONFIGURATIONS

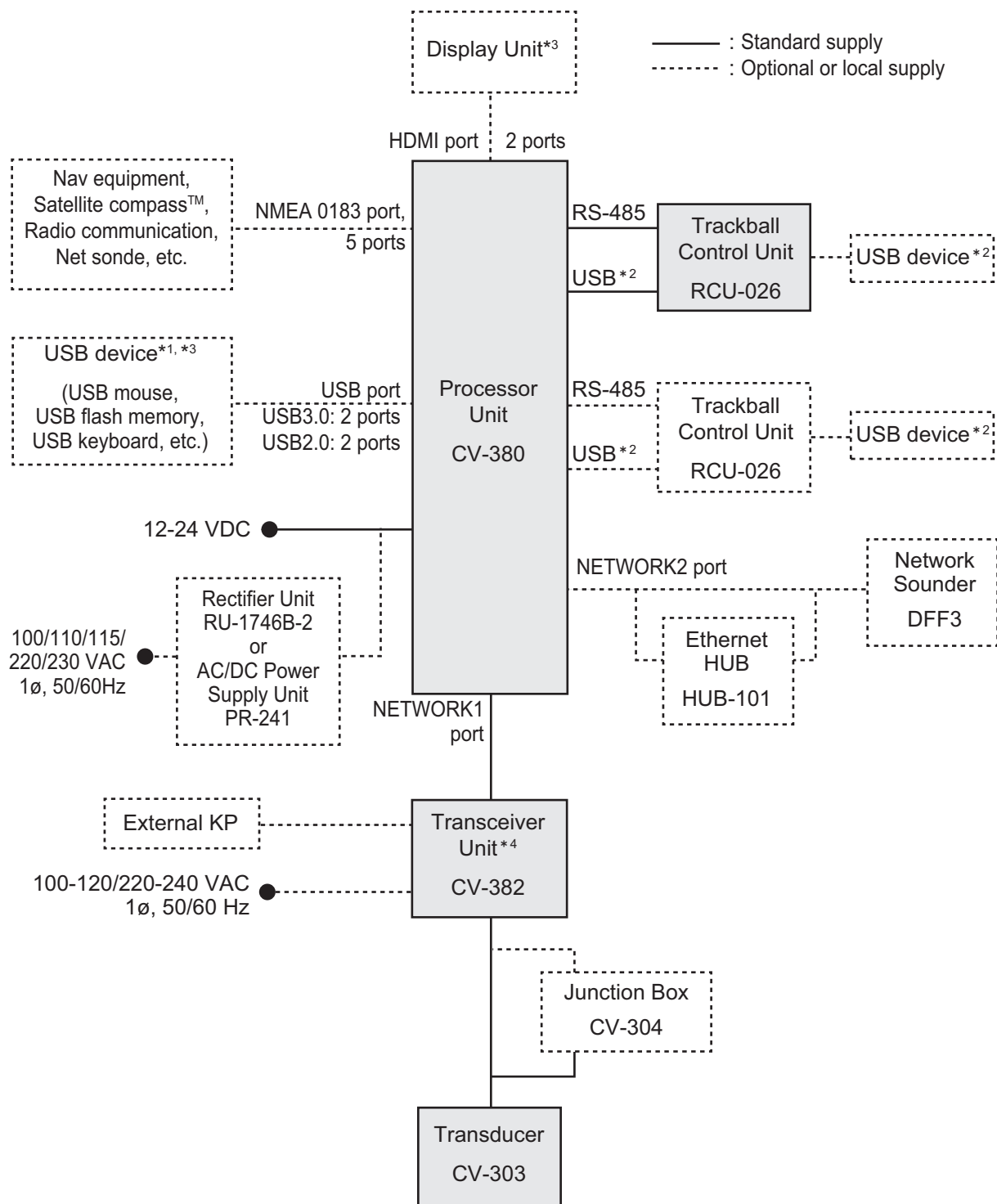

- *1: A maximum of four USB devices including RCU-026 can be connected to the processor unit.
- *2: To use the USB port on the RCU-026, connect the RCU-026 to the USB port on the processor unit, using the USB cable supplied with the RCU-026. If you do not use the USB port on the RCU-026, the USB connection between the RCU-026 and processor unit is not required.
- *3: To extend the distance between the processor unit and the monitor unit/USB device, use the optional DVI/USB repeater.
- *4: The transceiver unit CV-302 for FCV-30 is available.

EQUIPMENT LISTS

Standard supply

Name	Type	Code No.	Qty	Remarks	
Processor Unit	CV-380	-	1		
Transceiver Unit	CV-382	-	1		
Trackball Control Unit	RCU-026	-	1		
Transducer	CV-303 *ROHS*	-	1	15 m cable ($\phi 22$ mm), w/data sheet sticker (silver)	
Thru-Hull Pipe	TFB-1600	-	1		
Installation Materials	CP24-02900(10M)	001-208-050	1	LAN cable between processor unit and transceiver unit	10 m
	CP24-02910(20M)	001-208-060			20 m
	CP24-02920(30M)	001-208-070			30 m
Installation Materials	CP10-09700	000-036-275	1	For processor unit	
	CP02-09801	001-581-570	1	For transceiver unit	
	CP24-02300	000-027-673	1	For RCU-026	
Accessories	FP24-00801	001-418-410	1	For RCU-026	
Spare Parts	SP02-06001	001-569-280	1	For processor unit	
	SP03-17661	001-249-760	1	For transceiver unit	

Optional supply

Name	Type	Code No.	Remarks	
Junction Box	CV-304-10	-	10 m cable	
	CV-304-20	-	20 m cable	
	CV-304-50	-	50 m cable	
Rectifier Unit	RU-1746B-2	000-030-439		
AC/DC Power Supply Unit	PR-241	000-037-820		
Cable Assembly	HDMI-TO-DVI-L=10.3M	001-407-170	HDMI cable between processor unit and display unit	10.3 m
	HDMI-TO-DVI-L=5.3M	001-407-180		5.3 m
Ethernet Hub	HUB-101	000-011-762		
Cable Assembly	6TPSH-XH12X2-L5.0SP2	001-186-310-10	For RCU-026	5 m
	6TPSH-XH12X2-L10SP2	001-186-320-10		10 m
Flush Mount	OP24-27	001-171-820	For RCU-026	
Transducer Fixing Kit	T-625-A	001-096-720	For noise reduction caused by ship movement.	
Cable Assembly	PARTS_WO2511	001-578-140	LAN cable for DVI/USB repeater	30 m
	PARTS_WO2512	001-578-150		50 m
	PARTS_WO2513	001-578-160		100 m

Name	Type	Code No.	Remarks	
Installation Materials	CP10-10100	000-036-244	LAN cable between processor unit and transceiver unit (Waterproof type)	10 m
	CP10-10110	000-036-245		15 m
	CP10-10120	000-036-246		30 m
	CP10-10130	000-036-247		40 m
	CP10-10140	000-036-248		50 m
	CP10-10150	000-036-722		100 m
DVI/USB Repeater	TM000-FDX06_TXRX_30M	001-578-110	TX/RX units w/LAN cable	30 m
	TM000-FDX06_TXRX_50M	001-578-170		50 m
	TM000-FDX06_TXRX_100M	001-578-180		100 m
	TM000-FDX06_TXRX	001-578-190	TX/RX units	
	TM000-FDX06_RX	001-578-120	RX unit	
	TM000-FDX06_TX	001-578-130	TX unit	
Cable Assembly	MJ-A3SPF0024-035C	000-157-943-10		
	RNS-08-132	001-107-540-10	5 m cable between DVI/USB repeater (TX) and the processor unit	

This page is intentionally left blank.

1. MOUNTING

NOTICE

Do not apply paint, anti-corrosive sealant or contact spray to coating or plastic parts of the equipment.

Those items contain organic solvents that can damage coating and plastic parts, especially plastic connectors.

1.1 Processor Unit

The processor unit can be installed on a deck or bulkhead.

Mounting consideration

Select a mounting location, keeping in mind the following points:

- Locate the unit out of direct sunlight and away from heat sources.
- Locate the unit away from places subject to water splash and rain.
- Select a mounting location considering the length of the cables to be connected to the unit.
- Select a location where shock and vibration are minimal.
- Be sure the mounting location is strong enough to support the weight of the unit.
- Referring to the outline drawings at the back of this manual, allow sufficient space for maintenance and service.
- A magnetic compass will be affected if the unit is placed too close to the magnetic compass. Observe the compass safe distances at the front of this manual to prevent interference to a magnetic compass.
- For bulkhead installations, secure the unit so that the cable entrance faces downward.

1. MOUNTING

1.1.1 Deck mount

1. Drill four pilot holes in the mounting location for mounting bolts (M6 bolts or coach screws $\phi 6$), referring to the outline drawing at the back of this manual.
2. Secure the unit using the four hex head slot bolts (M6 \times 20, supplied).

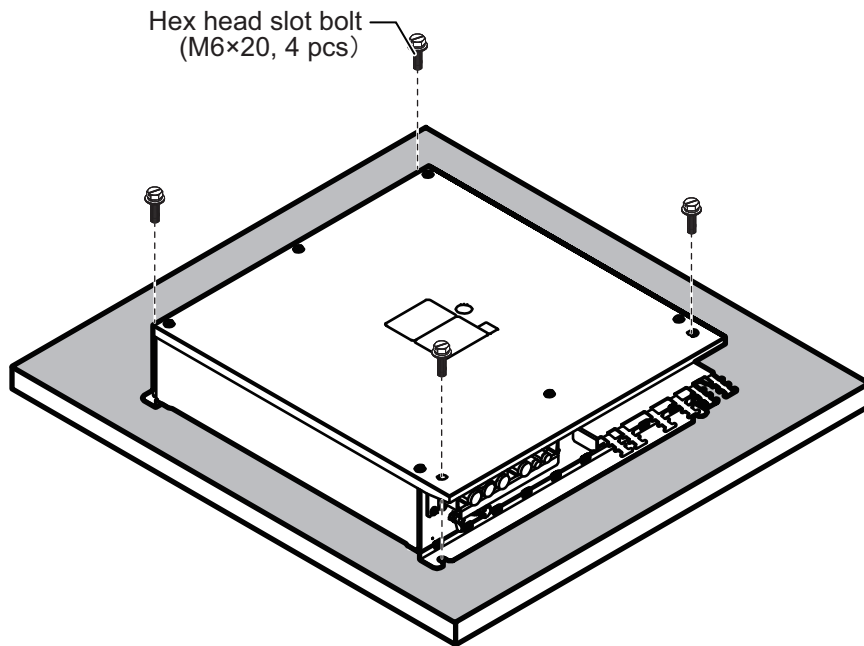

1.1.2 Bulkhead mount

1. Drill four pilot holes in the mounting location for mounting bolts (M6 \times 20, supplied), referring to the outline drawing at the back of this manual.
2. Screw two hex head slot bolts into the lower pilot holes. Leave 5 mm of thread visible.
3. Set the notches of the unit onto the screws fastened at step 2.
4. Screw two hex head slot bolts into the upper fixing holes.
5. Fasten all screws tightly to secure the unit in place.

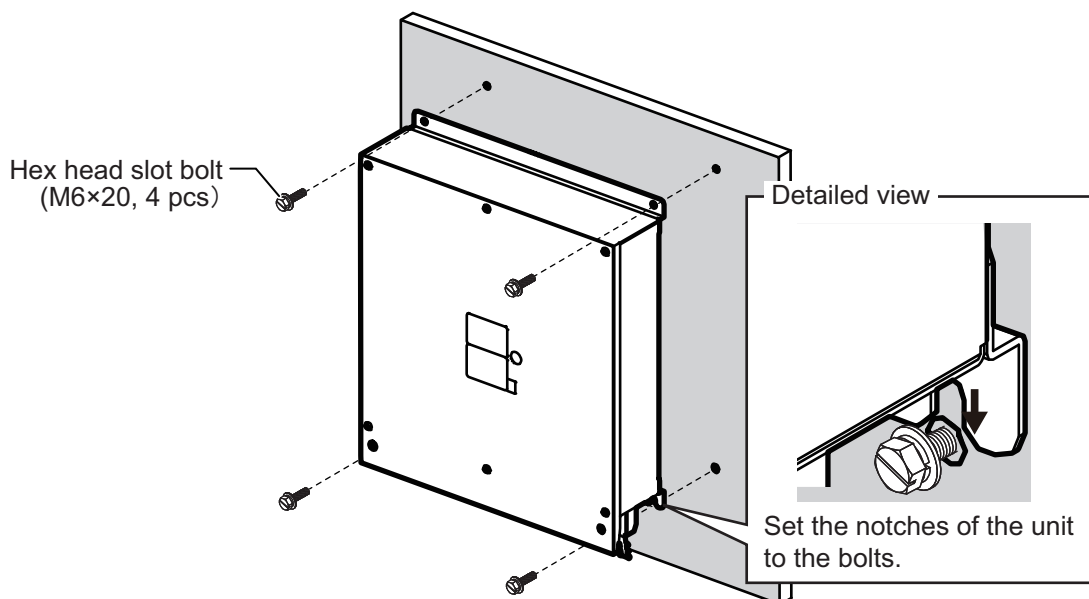

1.2 Transceiver Unit

The transceiver unit can be installed on a deck.

Mounting Consideration

Select a mounting location, keeping in mind the following points:

- The transceiver unit generates heat so the mounting location should be well ventilated and dry.
- Referring to the outline drawings at the back of this manual, allow sufficient space for maintenance and service.
- A magnetic compass will be affected if the unit is placed too close to the magnetic compass. Observe the compass safe distances at the front of this manual to prevent interference to a magnetic compass.
- If the front panel of the unit is oriented to port, its motion sensor faces the bow, i.e., the arrow mark of the NOTE label on the transceiver unit orients to bow. After installation, compensate for installation angle error, referring to chapter 3.

Deck Mount

1. If necessary, install a channel base on the mounting location, consulting with the shipyard.
Note: Take account of the direction of the transceiver unit. Position the transceiver unit so that the left side faces the bow as viewed from the cover side.
2. Drill four pilot holes in the mounting location for mounting screws (M12, supplied locally), referring to the outline drawing at the back of this manual.
3. Fasten the transceiver unit to the channel base with M12 bolts.
If necessary, reinforce the transceiver unit against vibration by stays extending from the eyebolts.

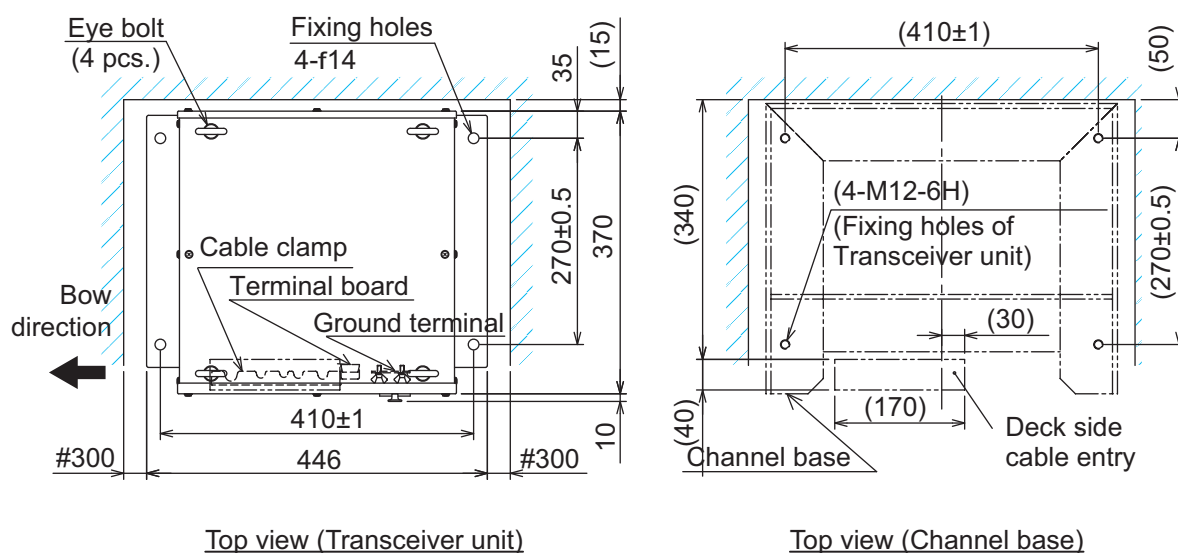

1.3 Trackball Control Unit

The trackball control unit can be installed on a desktop or flush mounting (option). For desktop mounting, the unit can be tilted or laid flat.

Mounting Consideration

Select a mounting location, keeping in mind the following points:

- Select a location where the control unit can be operated easily.
- Locate the unit out of direct sunlight and away from heat sources.
- Locate the unit away from places subject to water splash and rain.
- Referring to the outline drawings at the back of this manual, allow sufficient space for maintenance and service.
- Select a mounting location considering the length of the cables to be connected to the unit.
- A magnetic compass will be affected if the unit is placed too close to the magnetic compass. Observe the compass safe distances at the front of this manual to prevent interference to a magnetic compass.
- Select a location where shock and vibration are minimal.

1.3.1 Desktop mount

How to mount the unit tilted

Use the desk fixing plate to mount the unit tilted.

1. Attach the desktop fixing plate to the trackball control unit, using the two washer head screws (M3×8, supplied).

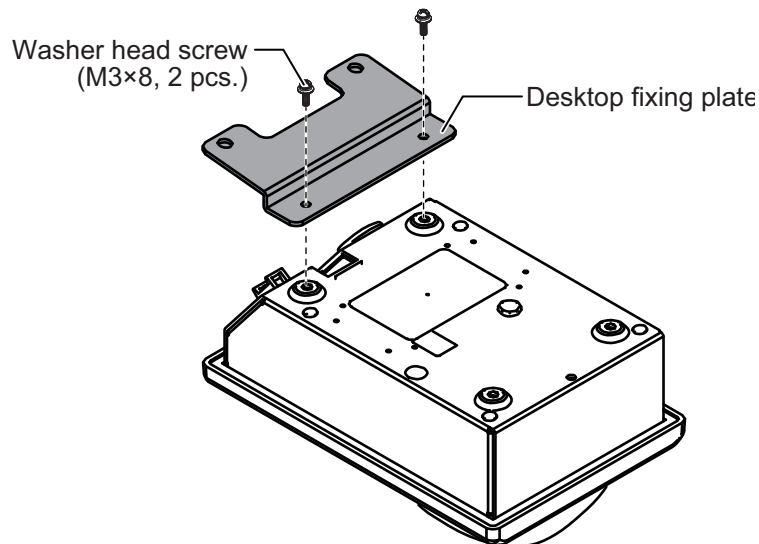

- Secure the unit using the two self-tapping screws ($\phi 5 \times 20$, supplied).

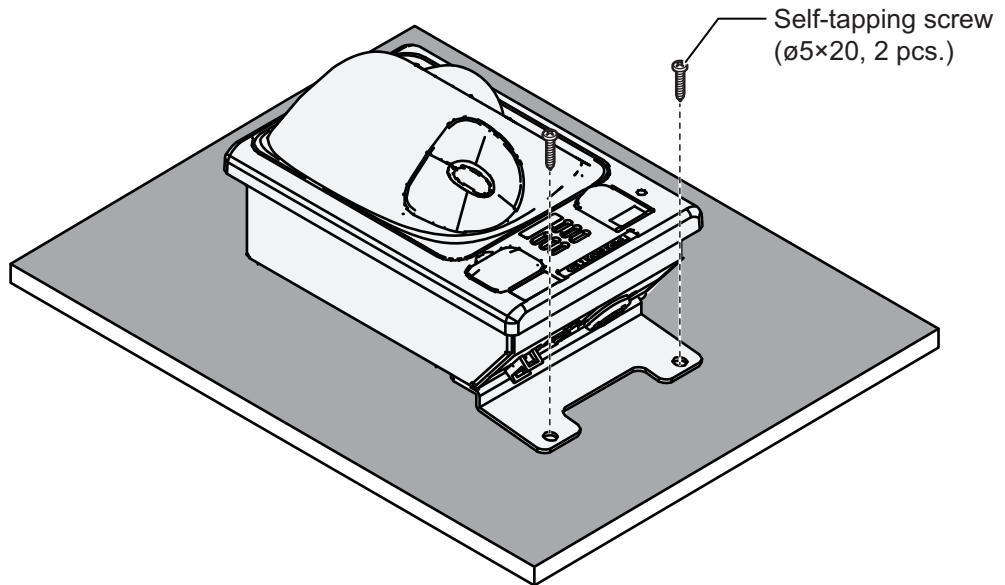

How to install the unit flat on the desktop

Secure the trackball control unit without the desktop fixing plate to install the unit flat on the desktop.

- Drill four mounting holes of 4 mm diameter referring to the outline drawings at the back of this manual.
- Secure the unit with the four washer head screws (M3 \times 12, supplied) from the underside of the desktop.

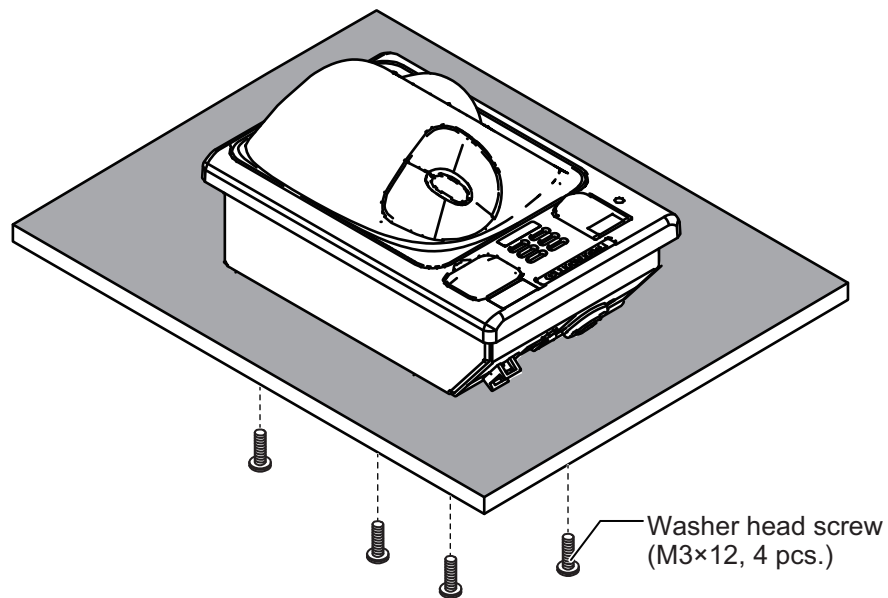

1. MOUNTING

1.3.2 Flush mount

Note: For flush mounting in a panel, the mounting surface must be flat. Do not install the unit on an uneven surface.

Prepare the optional flush mount kit (OP24-27) for flush mounting the trackball control unit.

1. Make a mounting hole in the mounting location, referring to the outline drawing at the back of this manual.
2. Set the unit to the mounting hole.
3. Attach the four FM fixing plates to the unit from the rear side, using the washer head screws (M3×8).

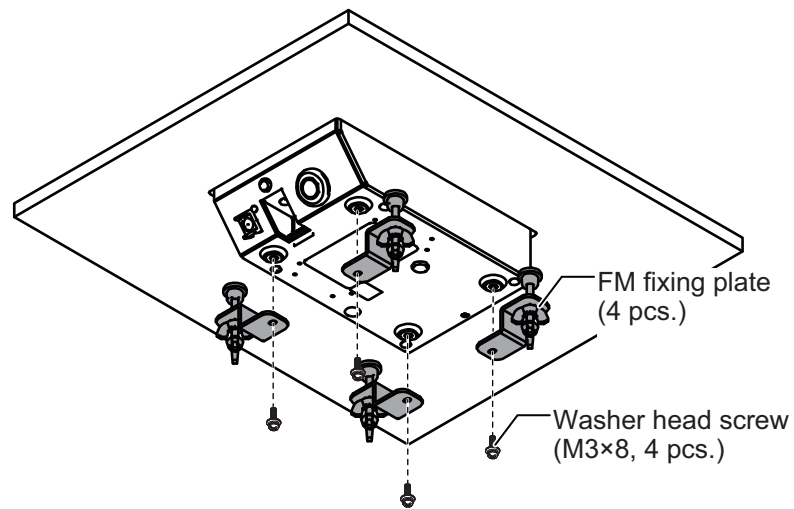

4. Fasten each wing bolt until the protector for the screw is firm against the mounting panel.
5. Fasten each wing nut tightly to secure the unit.

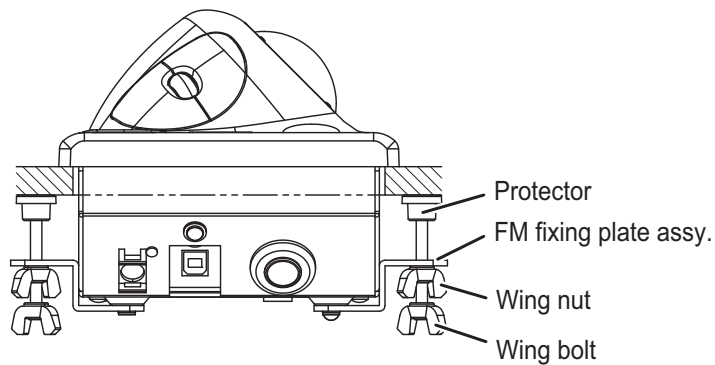

1.4 Transducer

NOTICE

Do not install the transducer on the inner side of the hull.
The signal strength is reduced and may affect the accuracy of measurements.

Do not cover the transducer with FRP resin.
The heat generated when the resin hardens may damage the transducer.
 For mounting the transducer, use a flange for transducer tank.

The performance of the fish finder depends on the transducer position.

Refer to the drawing for transducer tank installation at the end of this manual. The transducer tank T-625 (code: 000-037-649) should be prepared locally.

Mounting consideration

Note 1: Carefully handle the transducer. Do not lift the transducer by holding the cable, nor drop it.

Note 2: The gasket sizes in the thru-hull pipe are different for two types of CV-303. When replacing the transducer, make sure that the gasket in the thru-hull pipe is applied with the cable.

If the gasket is required, arrange the appropriate gasket according to the cable diameter.

Cable diameter	Color of data sheet sticker*	Gasket of TFB-1600		Remarks
		Name	Type	
22.0 mm	Silver	Gland gasket B	02-153-4204	
19.4 mm	White	Gland gasket	02-153-4203	Cable for FCV-30

- A place least affected by air bubbles should be selected since turbulence blocks the sounding path.
- Select a place least influenced by engine noise.
- Select a place without other sounder interference. The transducer should be separated from other transducers with the same frequency by 2.5 m or farther.
- Install the transducer face parallel to the sea surface.
- Orient the transducer bow mark to ship's bow within ± 5 degree.

It is known that air bubbles are fewest at the place where the bow first falls and the next wave raises, at usual cruising speed. In small, slow-speed boats, the position between 1/3 and 1/2 of the ship's length from the bow is usually a good place.

Refer to the installation drawing for the transducer, combined with the thru-hull pipe TFB-1600.

Note: The face of the transducer must be facing the sea bottom in normal cruising trim of the boat.

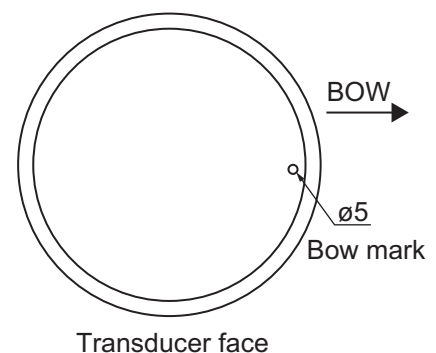

1. MOUNTING

Data sheet sticker

The transducer is supplied with three data sheet stickers **in silver** on the transducer cable as follows. Refer to section 3.2.6.

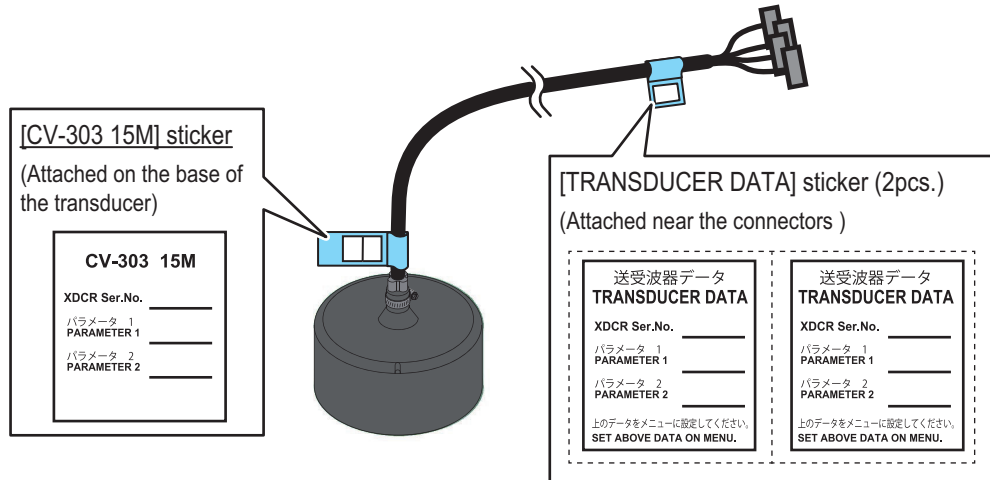

Note: If the data sheet stickers in white (Not in silver) are attached on the cable for FCV-30, conductive tape should be wound around the exposed shield. See section 2.4 for details.

1.4.1 About transducer casing

The FURUNO transducer tank is finished with lacquer primer to prevent corrosion in storage. After welding the casing to ship's hull, remove the lacquer primer, using lacquer thinner. Coat casing with same paint as used on the ship's hull.

Methods to remove lacquer primer from the tank

1. Dissolve and remove paint with solvent.
2. Remove rust, coating, oil film, etc, with a blaster.
3. Remove with a disk sander or foil brush.

1.4.2 Transducer fixing plate kit (option) assembly

You can use the optional T-625-A transducer fixing plate kit to reduce noise caused by ship movement for transducer tank T-625 (local supply).

1. Remove the press plate from the transducer fixing plate and fit the fixing plate to the transducer.

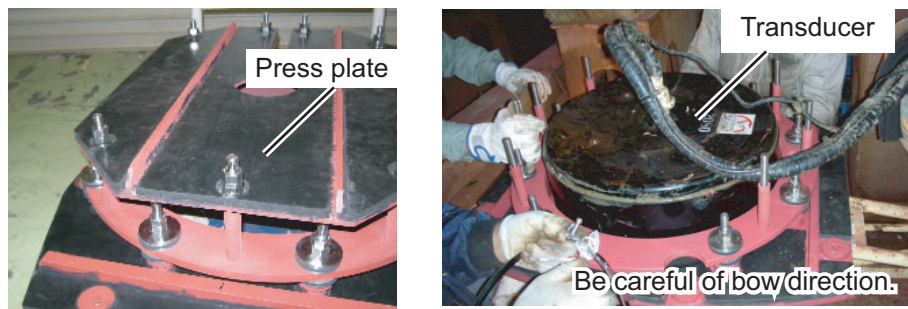

Transducer fixing plate

2. Wrap the two flank sponges around the sides of the transducer. Face the cut side toward the transducer and insert the uncut part between the transducer and the TD attachment.

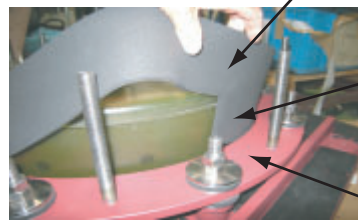
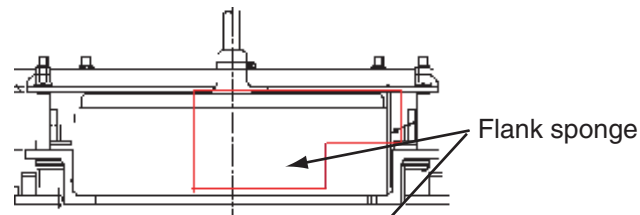

- Insert the uncut part between the transducer and the TD attachment.
- TD attachment

3. Secure the sponge in place with a hose clamp (stainless band). Apply silicone sealant (local supply) to the screws to prevent seizing and corrosion.

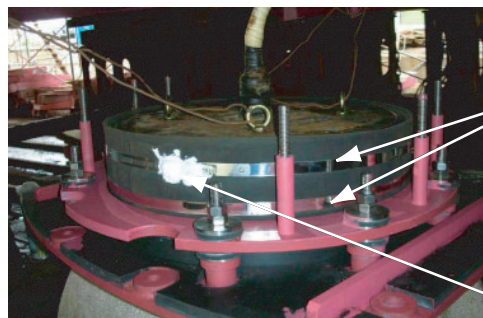

- Stainless band
- Silicone sealant

4. Refit the press plate as before. Tighten the double nuts at 63.5Nm torque.

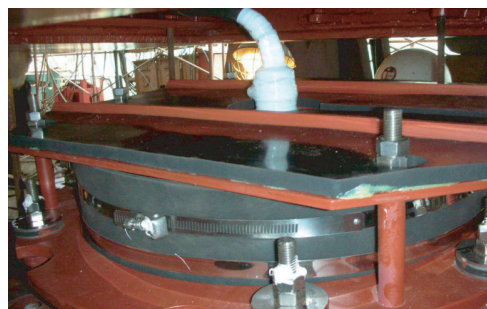

5. To attach to the ship's bottom, refer to the T625 tank drawing.

1.5 Junction Box (Option)

If the length of cable between the transducer and transceiver unit is more than 15 m, the optional junction box CV-304 (with 10 m, 20 m or 50 m cable) can be used for cable extension.

Keep in mind the following points when selecting a location.

- Leave sufficient space at the sides and rear of the unit to facilitate maintenance.
- A magnetic compass will be affected if the junction box is placed too close to the magnetic compass. Observe the compass safe distances in "SAFETY INSTRUCTIONS" on page i to prevent interference to a magnetic compass.
- Connect a copper strap (local supply) to the ground terminal.

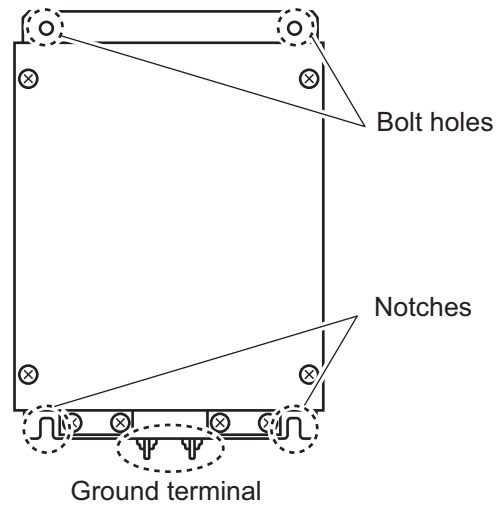

Use four bolts (M5, local supply) to secure the junction box.

For bulkhead mounting, fasten two bolts for the lower notches, leaving 5 mm of thread exposed from the bolt head. Set the notches of the junction box on the two bolts, the fasten two bolts for the upper bolt holes. Secure the junction box in place with all four bolts fastened tightly.

Note: For bulkhead installations, the cable entry must face downwards.

1.6 DVI/USB Repeater (Option)

To extend the distance between the display unit and the processor unit/USB device, use the optional DVI/USB repeater. Cable extension without the repeater can result in signal loss and incorrect data display.

The DVI/USB repeater has two units, one transmitter unit and one receiver unit. The following figure shows the general connection for the DVI/USB repeater.

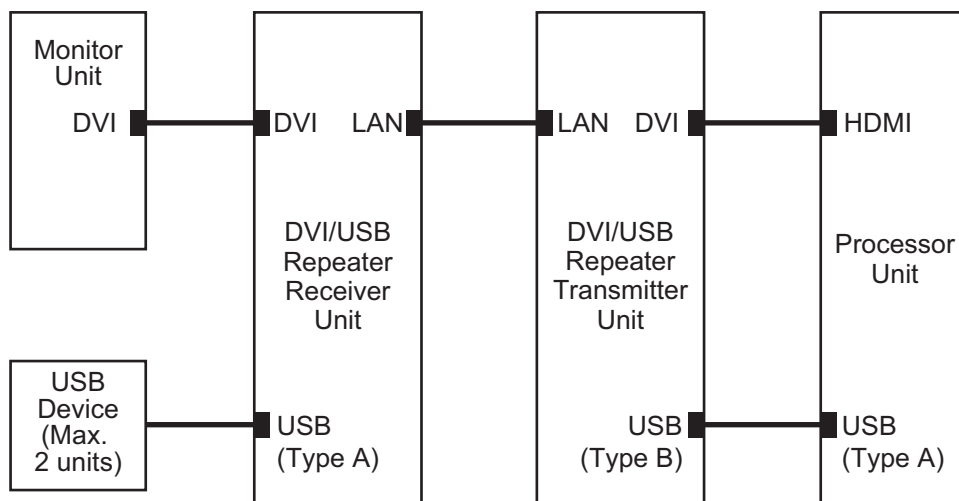

The DVI/USB repeater can be installed on a deck or bulkhead. Cable connection is slightly different between transmitter and receiver unit. For this reason, it is important that you identify each unit before mounting. The following table and figure show how to identify the units.

Unit	What to look for
Receiver Unit	Female SRCN connector, USB type A connector × 2
Transmitter Unit	Male SRCN connector, USB type B connector

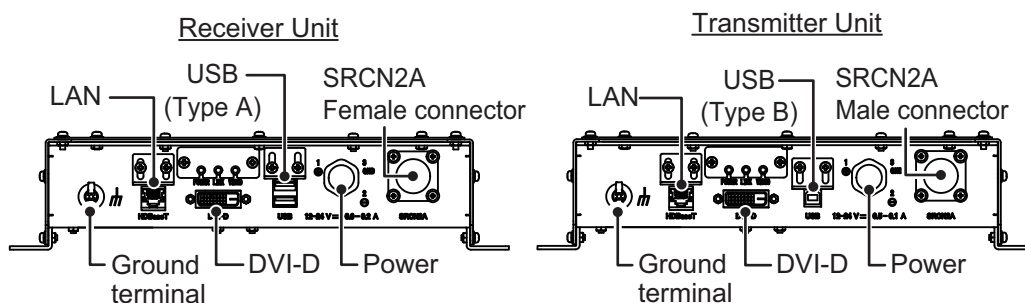

Mounting consideration

- Locate the unit away from heat sources.
- Locate the unit away from places subject to water splash and rain.
- Select a mounting location considering the length of the cables to be connected to the unit.
- Select a location where shock and vibration are minimal.
- Referring to the outline drawings at the back of this manual, allow sufficient space for maintenance and service.
- A magnetic compass will be affected if the unit is placed too close to the magnetic compass. Observe the compass safe distances at the front of this manual to prevent interference to a magnetic compass.
- For bulkhead installations, secure the unit so that the cable entrance faces downward.
- The maximum cable length for the video signal cable is as follows:
 - HDMI-TO-DVI-L cable between processor unit and transmitter unit: 5.3 m
 - DVI-D/D S-LINK cable between receiver unit to monitor unit: 5 m

1. MOUNTING

Mounting procedure

1. Drill four pilot holes in the mounting location for mounting screws ($\phi 5 \times 20$, local supply), referring to the outline drawing at the back of this manual.
2. Screw the four self-tapping screws into the pilot holes. Leave 5 mm of thread visible.
3. Hang the unit onto the screws fastened at step 2.
4. Fasten all screws tightly to secure the unit in place.

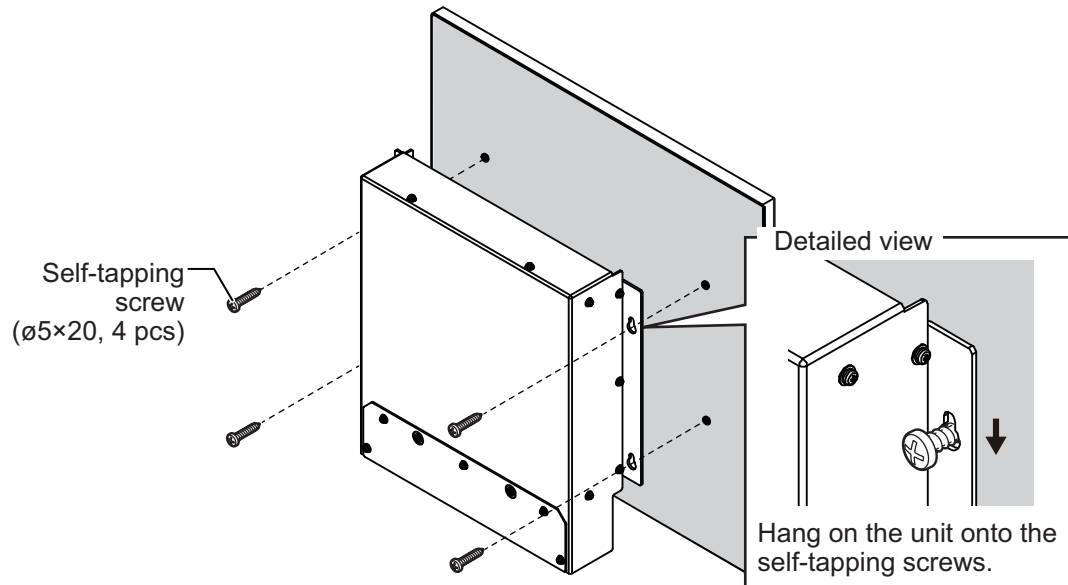

2. WIRING

The illustration on this page shows the general connections for the FCV-38. For detailed information, see the interconnection diagram. Many of the cables mentioned are JIS (Japanese Industrial Standards) cables. If not available locally, use the equivalent. See the cable guide in the Appendix for how to select equivalent cables.

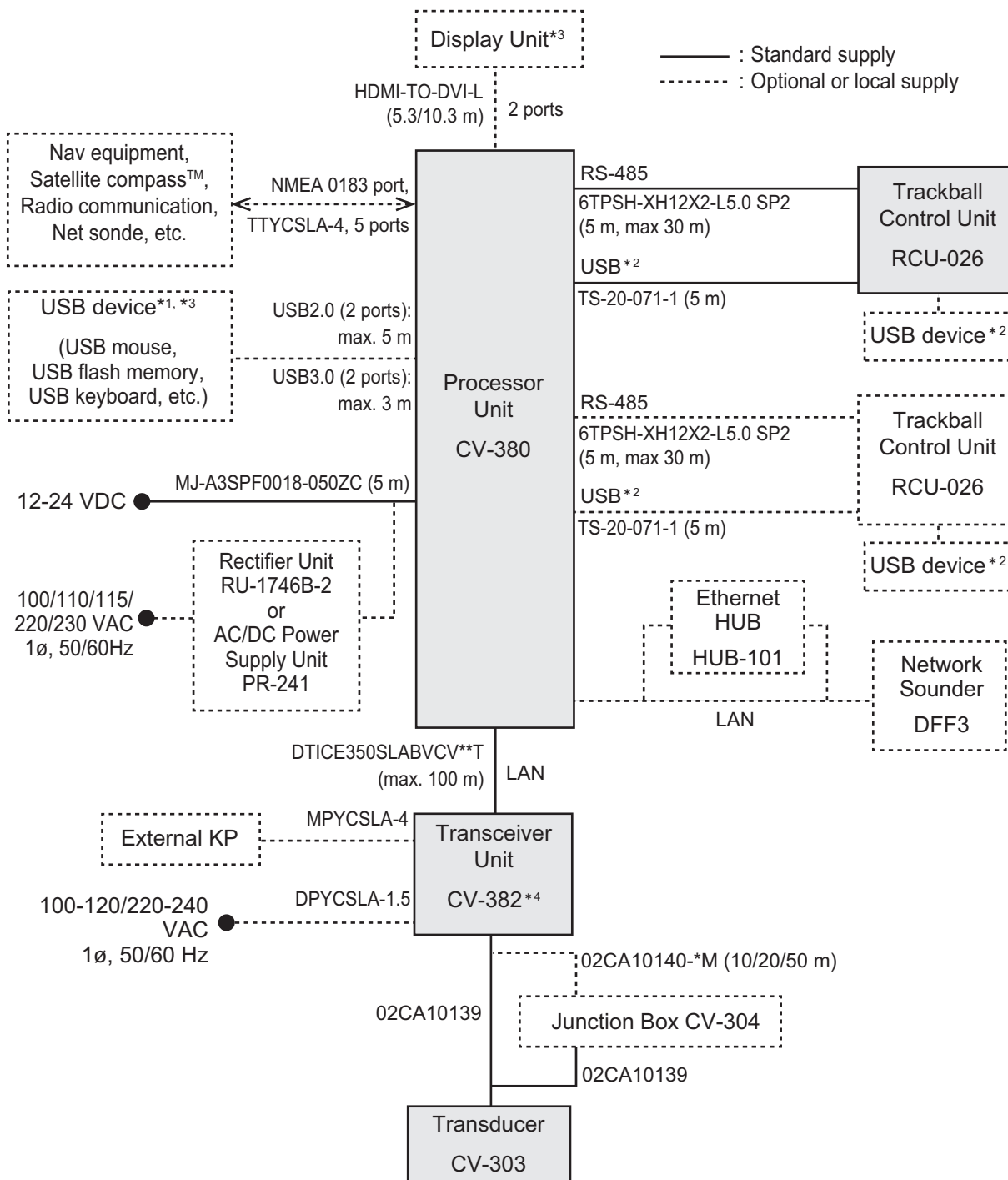

*1: A maximum of four USB devices including RCU-026 can be connected to the processor unit.

*2: To use the USB port on the RCU-026, connect the RCU-026 to the USB port on the processor unit, using the USB cable supplied with the RCU-026. If you do not use the USB port on the RCU-026, the USB connection between the RCU-026 and processor unit is not required.

*3: To install the processor unit apart from the monitor unit and USB device, use the optional DVI/USB repeater.

*4: The transceiver unit CV-302 for FCV-30 is available.

2.1 Processor unit

2.1.1 Wiring overview

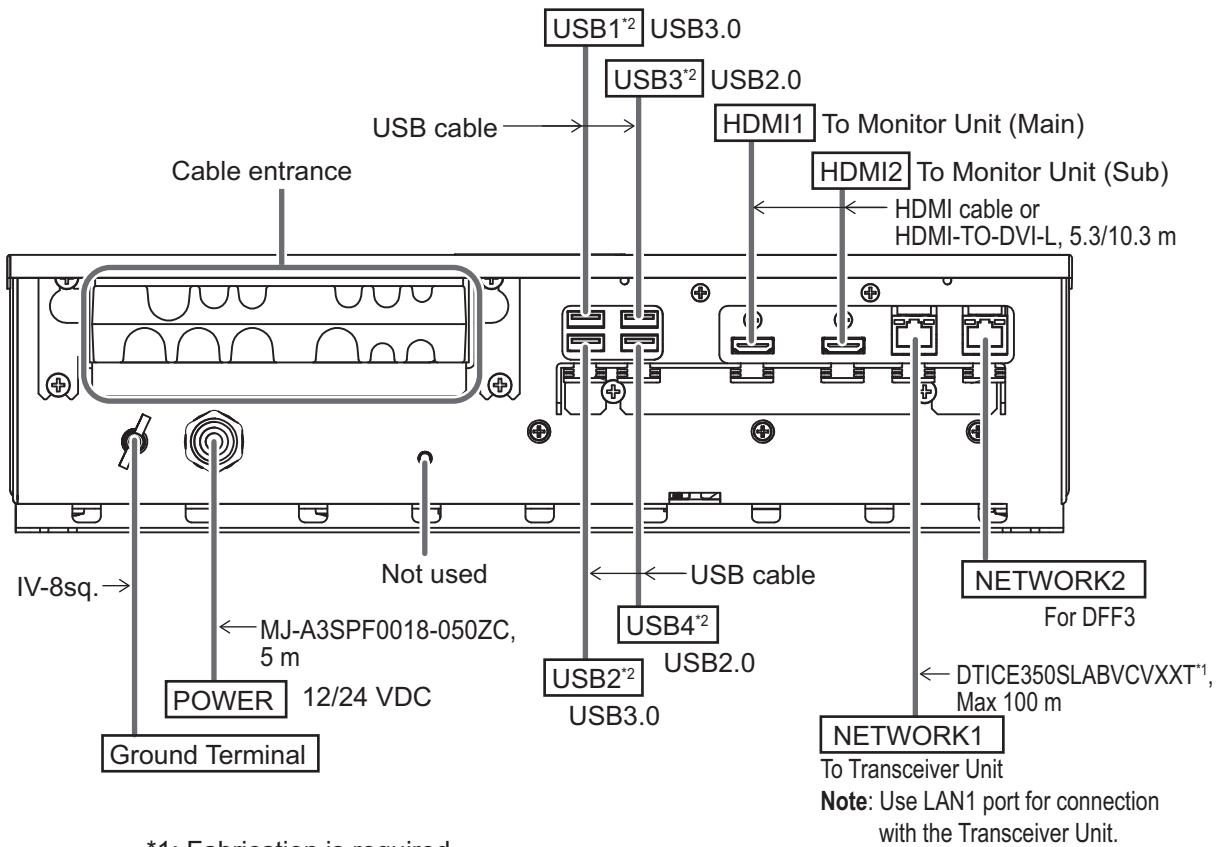

*1: Fabrication is required.

*2: To connect a USB device, use the lower USB port first.

Secure the USB, HDMI and LAN cables to the cable clamp with a cable tie (local supply). For the USB cables, use two cable ties for each cable.

Note 1: The cable clamp can be adjusted to allow larger connectors, such as USB or HDMI, to be connected.

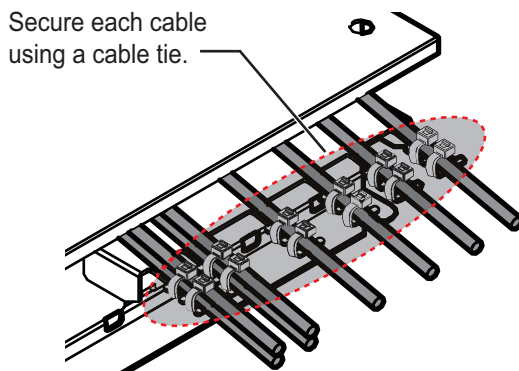

Unfasten the indicated screws to adjust the cable clamp. Refasten the screws to secure the cable clamp after adjustment.

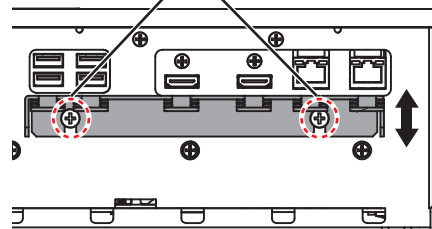

Note 2: The maximum cable length for USB2.0 and USB3.0 is as follows. To extend the USB cable, the optional DVI/USB repeater is required. If you extend the USB cable without the DVI/USB repeater, the USB device operation is not guaranteed.

- USB2.0: Max. 5 m
- USB3.0: Max. 3 m

2.1.2 Internal wiring and cable clamp position

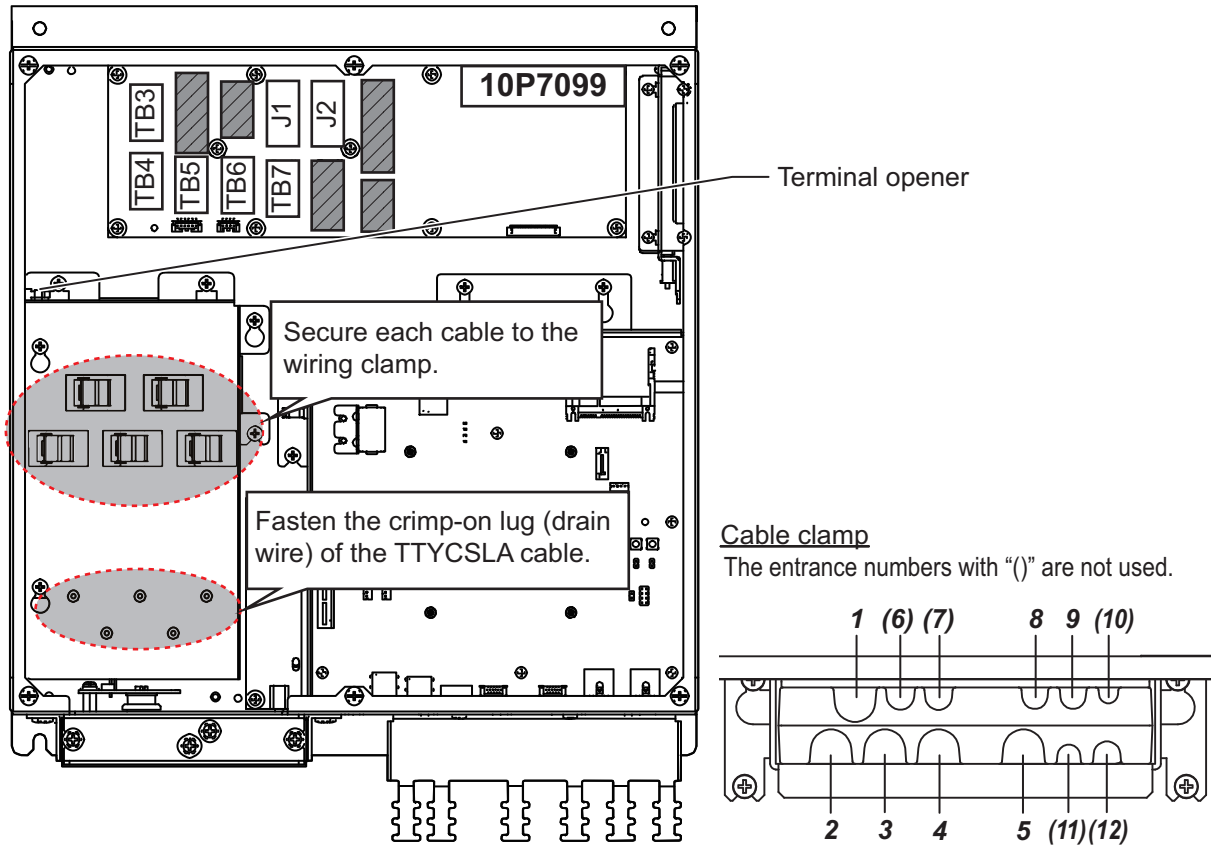

Clamp position	Connect to	Cable from	Cable
1	TB3	NMEA0183 equipment	TTYCSLA-4*1
2	TB4		
3	TB5		
4	TB6		
5	TB7		
6 to 7	—	Not used	—
8	J1	Control unit	—
9	J2	Control unit	—
10 to 12	—	Not used	—

*1: The cable fabrication is required. See section 2.1.3

DIP switch setting

Set the DIP switches on the PIF board (10P7099) as follows.

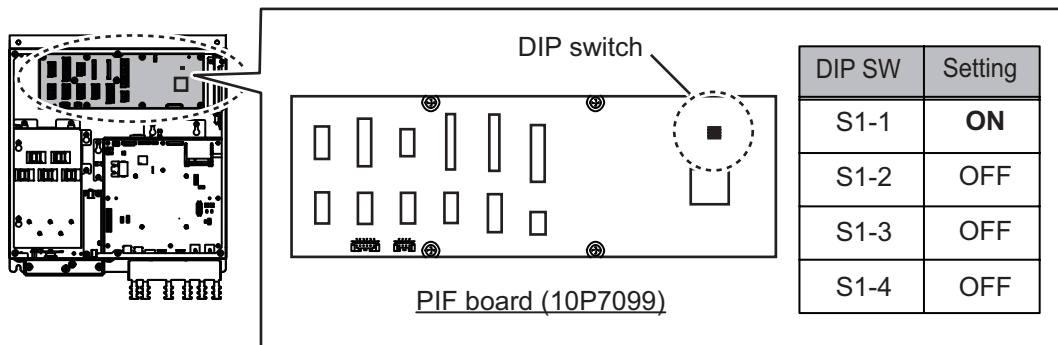

2.1.3 Cable fabrication

LAN cable

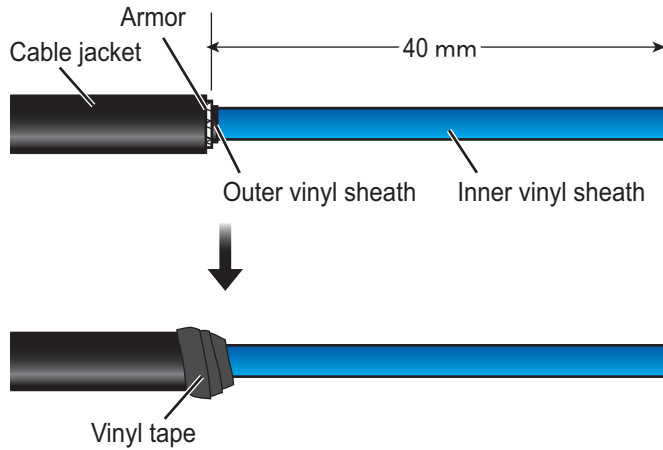

<How to attach a modular plug>

After fabricating the cable, attach the modular connector.

Note: This equipment only uses straight cables. Use a CAT5E LAN cable.



Expose inner vinyl sheath.



Remove the inner vinyl sheath by approx. 25 mm. Be careful not to damage inner shield and cores.

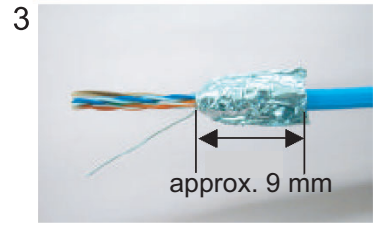

Fold back the shield, wrap it onto the inner vinyl sheath and cut it, leaving approx. 9 mm.

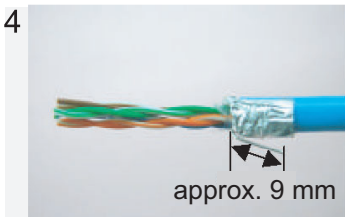

Fold back drain wire and cut it, leaving approx. 9 mm.

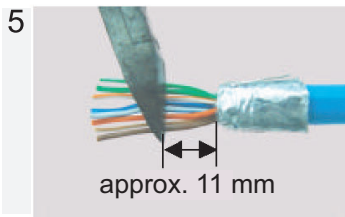

Straighten and flatten the cores in colored order and cut them, leaving approx. 11 mm.

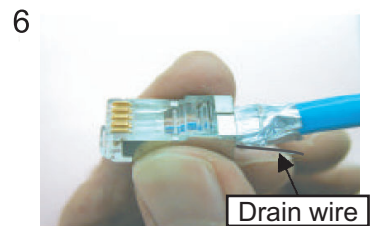

Insert the cable into the modular plug so that the folded part of the shield enters into the plug housing. The drain wire should be located on the tab side of the jack.



Using special crimping tool MPT5-8AS (PANDUIT CORP.), crimp the modular plug. Finally, check the plug visually.

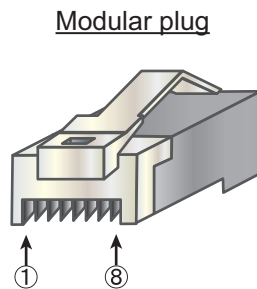

[Straight cable]

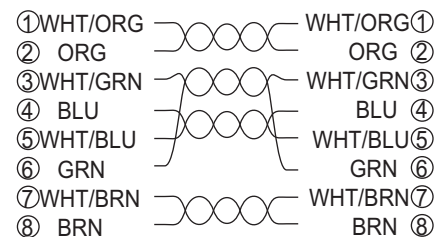

TTYCSLA cable

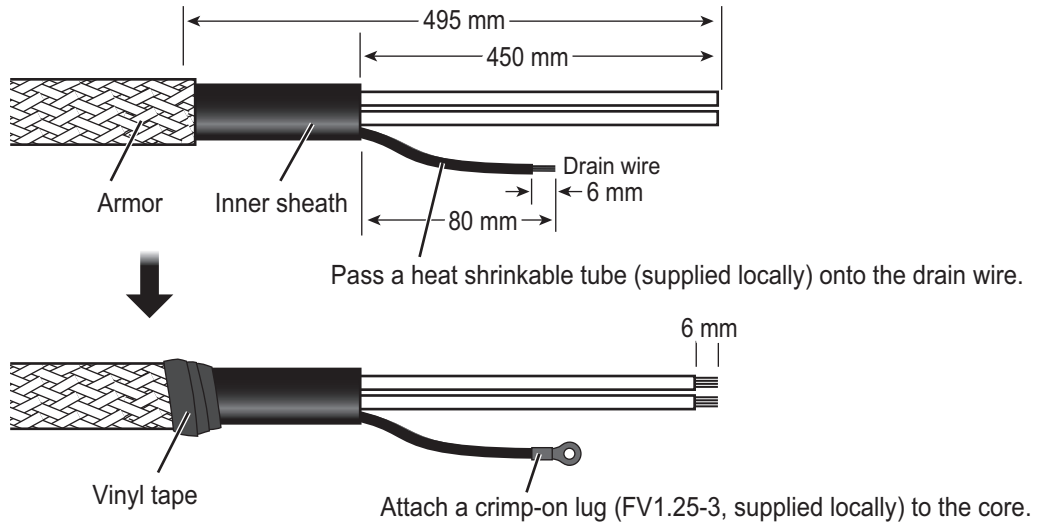

<How to connect wires to a terminal connector>

Press downward.
Terminal opener
Terminal connector
Twist

Procedure

1. Twist the cores.
2. Press the terminal opener downward.
3. Insert the wire in the hole.
4. Remove the terminal opener.
5. Pull the wire to confirm that it is secure.

2.1.4 How to change the fuse

Change the fuse in the fuse holder on the power cable according to the input voltage, referring to the following table. Fuses are supplied as spare parts.

Input voltage	Rating of fuse
12 VDC	15 A (factory default)
24 VDC	7 A

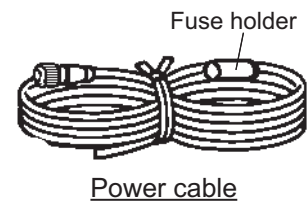

⚠ WARNING

⚠ Use the proper fuse.

Fuse rating is shown in the table below. Use of a wrong fuse can result in damage to the equipment.

2.2 Transceiver Unit

2.2.1 Cable fabrication

LAN cable

For how to attach the modular plug, see page 2-3.

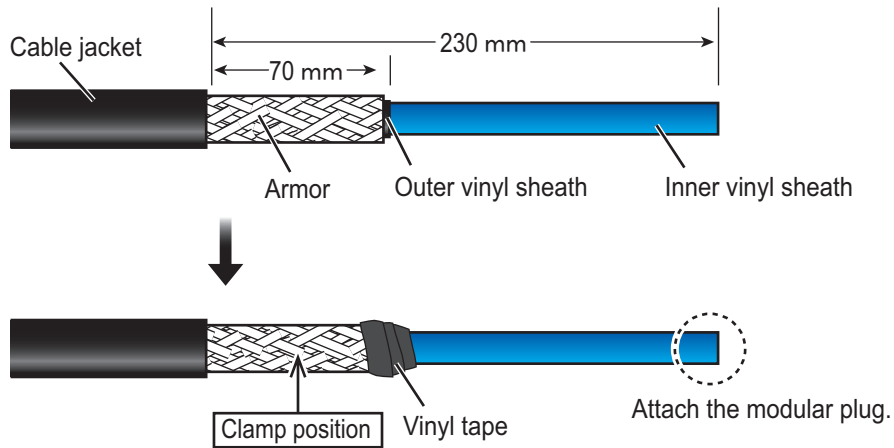

Cable for external KP (MPYCSLA-4)

For how to attach the terminal block connector, see page 2-5.

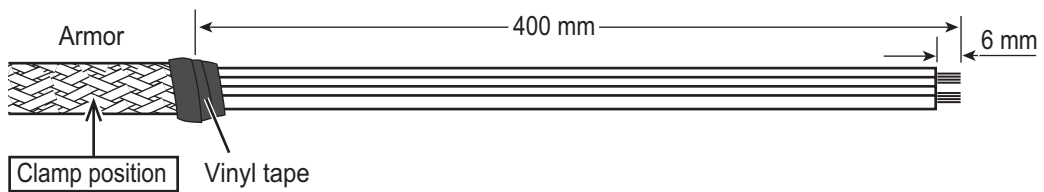

Power cable (DPYCSLA-1.5)

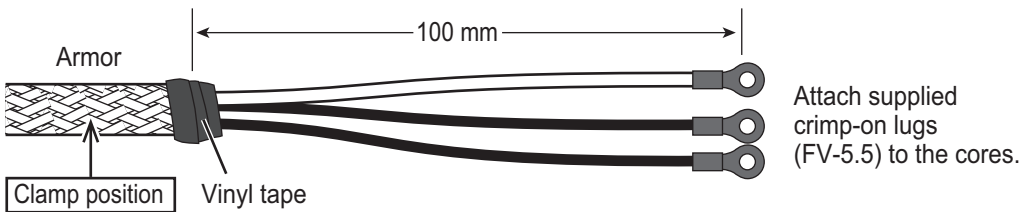

2.2.2 Wiring

Connect the following cables as shown in the figure below.

Note: Prepare a **box wrench** (local supply, Hex. size 8 mm) to secure the cable clamp.

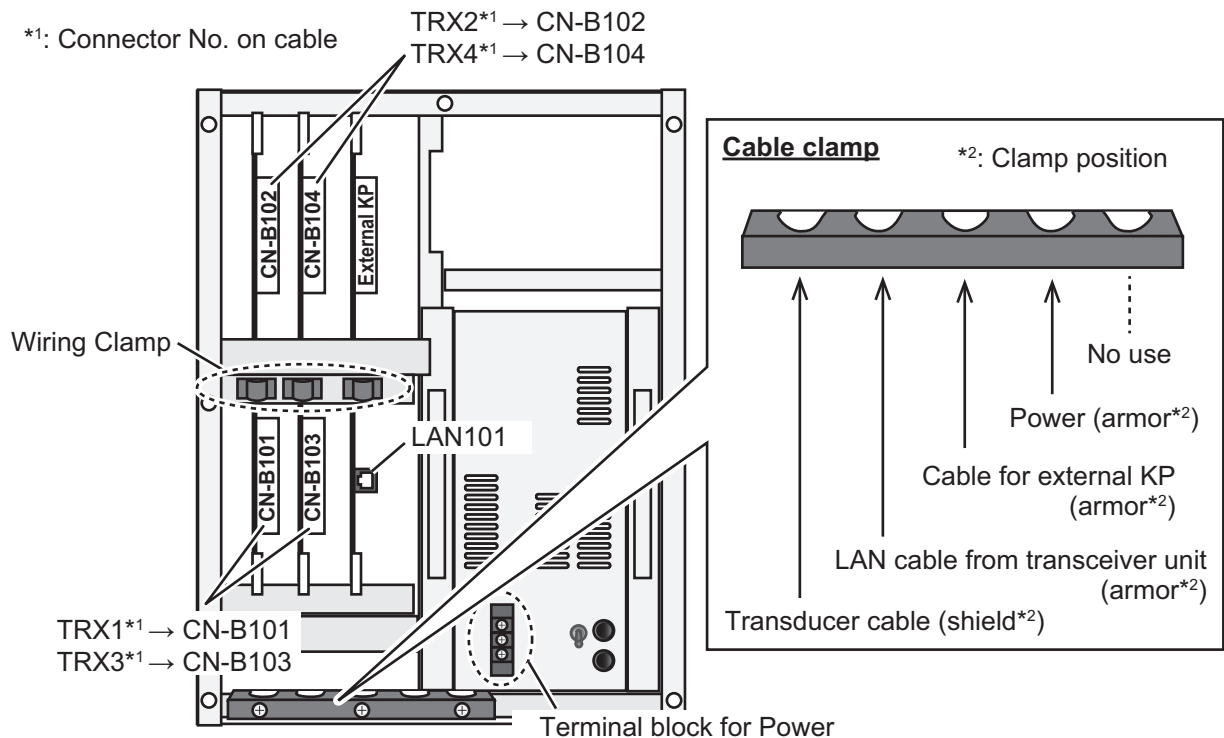

1. Loosen the seven screws on the cover of the transceiver unit to remove the cover.
2. Remove the three screws on the cable clamp with a box wrench (Hex. size 8 mm).
3. Pass the following cables through the appropriate cable entrances of the cable clamp, then secure the cables with the cable clamp, referring to the figure above.
 - Transducer cable: Clamp at the shielded section of the cable.
 - LAN cable: Clamp at the armored section of the cable.
 - Cable for external KP: Clamp at the armored section of the cable.
 - Power cable: Clamp at the armored section of the cable.
4. Connect the following cables to the appropriate connectors, referring to the wiring label attached on the back of the cover.
 - Transducer cable: Connect the connectors TRX1 to TRX4 on the cables to the connectors CN-B101 to B104 on the chassis via appropriate wiring clamp.
 - LAN cable: Connect to LAN101 connector.
 - Cable for external KP: Connect External KP connector via appropriate wiring clamp.
 - Power cable: Connect to the terminal block for power cable.
5. Reattach the cover of the transceiver unit.

DIP switch setting

Set the DIP switches on the HMS board (10P7099) as follows.

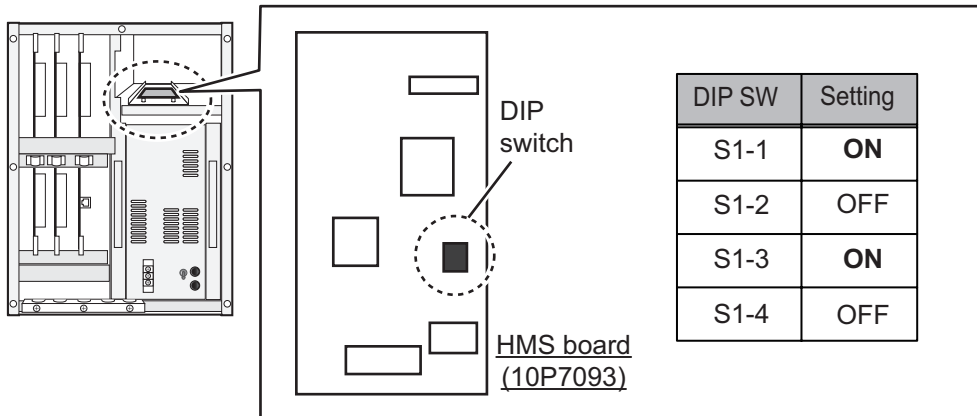

2.3 Trackball Control Unit

Connect the control unit cable to the processor unit (J1 or J2). To use the USB port on the trackball control unit, connect the unit to either one of the USB ports on the processor unit, using the supplied USB cable (TS-20-071-1). Note that the trackball control unit cannot be operated if only a USB cable is connected on the processor unit. If the USB port on the trackball control unit will not be used, the USB connection between the trackball control unit and processor unit is not required.

Connect a ground wire (IV-1.25sq., local supply) between the ground terminal and ship's ground.

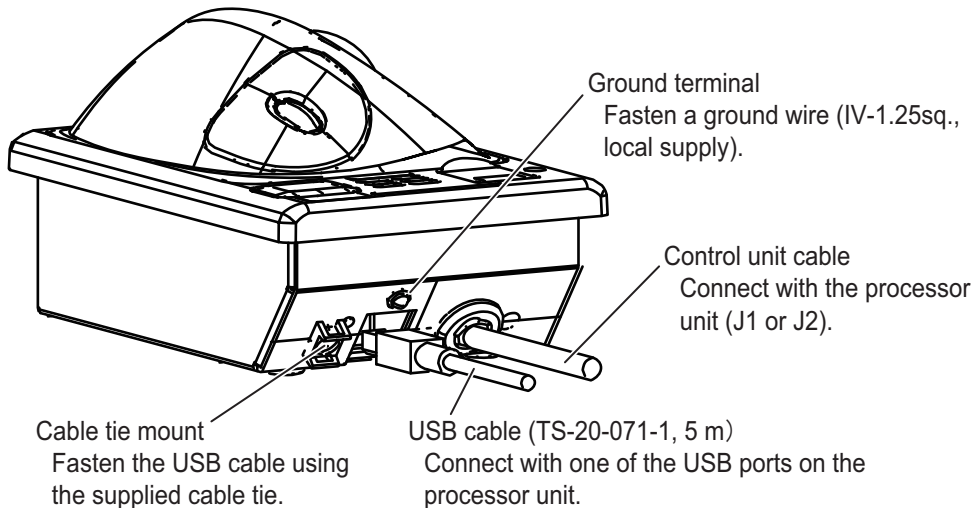

Note 1: If the USB cable is connected to the trackball control unit, fasten the USB cable to the cable tie mount using the supplied cable tie.

Note 2: The maximum cable length for USB2.0 is 5 m. To extend the USB cable, the optional DVI/USB repeater is required. If you extend the USB cable without the DVI/USB repeater, the USB device operation is not guaranteed.

Note 3: The supplied USB cable and USB port on the trackball control unit do not support USB3.0. The USB port on the trackball control unit is available, even if the sup-

plied USB cable is connected to USB3.0 port on the processor unit. However, the data transfer speed is equivalent to USB 2.0.

Note 4: If the USB cable will not be connected to the trackball control unit, attach the supplied USB sheet to the USB port on the trackball control unit.

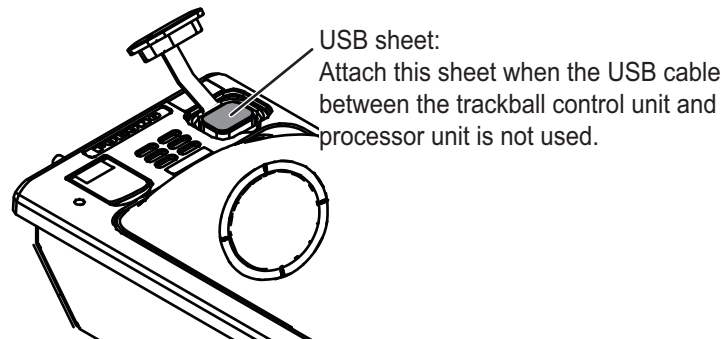

How to extend the control unit cable

To extend the length of the cable between the trackball control unit and the processor unit, use the optional cable assembly (6TPSH-XH12X2-LxxSP2, 5/10 m).

1. Unfasten four binding screws (M3×8) from the bottom of the unit, and a pan head screw (M3×8) and flat washer from the back of the unit to remove the cover.

Note: Remove the cover slowly to prevent damage to the cables connected to the circuit board in the unit.

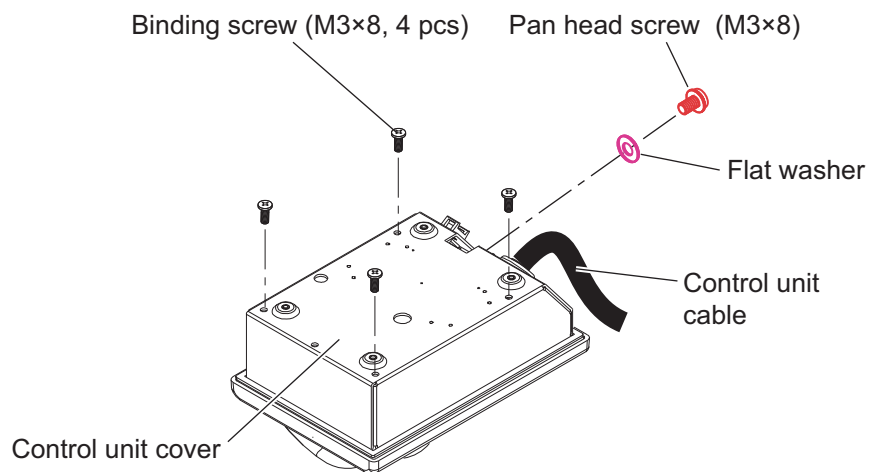

2. WIRING

2. Unfasten the binding screws (indicated in the following figure) to remove the cable clamp from the trackball control unit, then disconnect the control unit cable from J1.

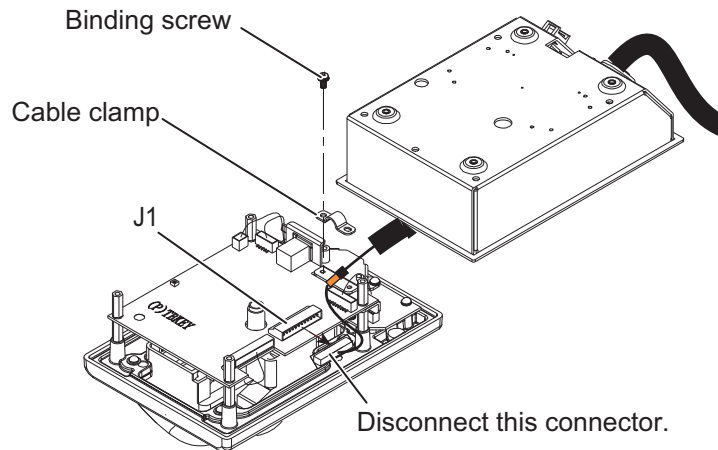

3. Pull out the control unit cable from the cover.
4. Pass the optional cable assembly (6TPSH-XH12X2-LxxSP2) through the cable hole on the cover.

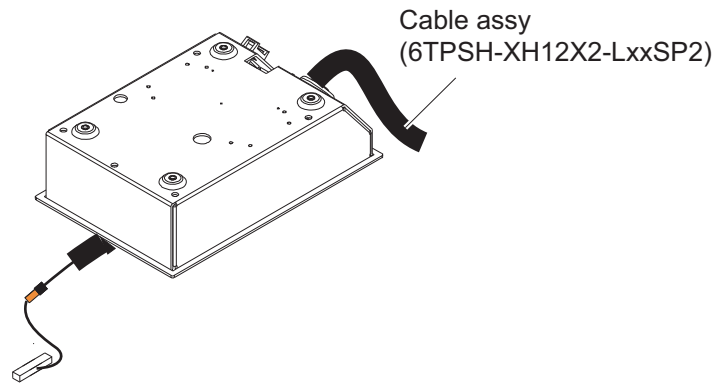

5. Fasten the shield of the cable assembly with the cable clamp (removed at step 2), then connect the connector at the end of the cable assembly to the J1 connector on the circuit board.

Note: The shield of the cable must not touch the circuit board.

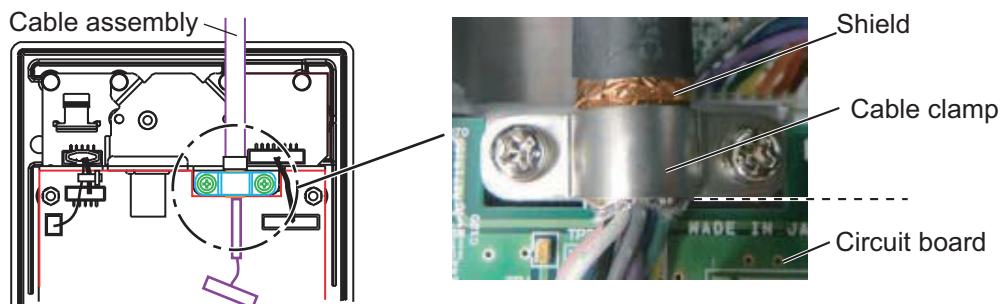

6. Reattach the control unit cover.

2.4 Transducer

The transducer with a cable diameter 22.0 mm should be installed. Check that the data sheet sticker on the transducer cable is in silver.

If a pre-installed transducer has a cable with a diameter 19.4 mm (in this case, transducer cable with the data sticker in “white”), wind the conductive tape supplied in CP02-09801 around the center of the shielded section of the cable. If a conductive tape supplied locally is used, keep in mind the following points:

- Tape size: width 25 mm × length 600 mm
- Conductive copper tape on the adhesive surface

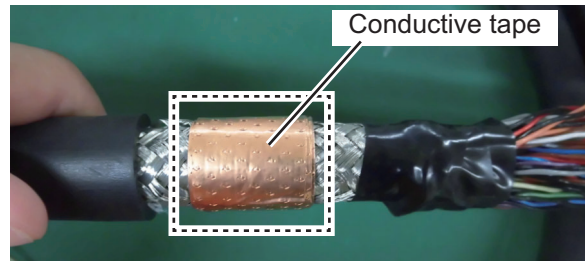

Note: For the cables with a diameter 22.0 mm, conductive tape is not required.

2.5 Junction Box (option)

Connect the ground wire between the ground terminal on the chassis and the ship's earth, referring to section 1.5.

How to open/close the top cover

Unfasten four screws to open the top cover from the junction box.

After the appropriate cable connections are completed, replace the cover then fasten the four screws.

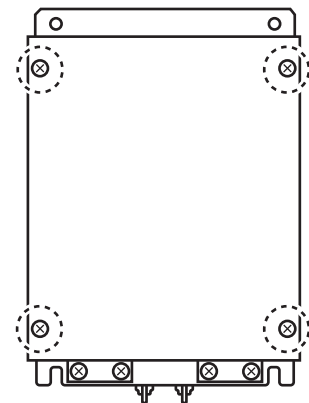

Cable Connection

Unfasten the four screws on the cable clamps, pass the cables (from the transceiver and transducer) through the clamps. Connect the cables to their respective connectors in the Junction Box. Fasten the four screws to secure the cables with the clamps.

2. WIRING

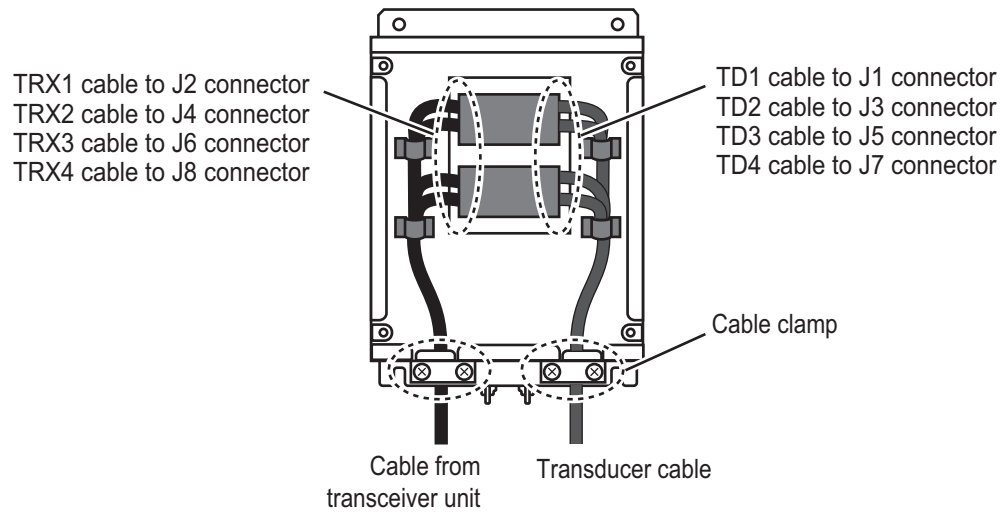

2.6 DVI/USB Repeater (Option)

You can install the processor unit apart from the monitor unit and USB device by using the optional DVI/USB repeater. Cable extension without the repeater can result in signal loss and incorrect data display.

To access the connectors on the transmitter and receiver units, unfasten five screws and remove the protective cover. For the connections between the units, see the following connection diagram.

Note 1: Make sure that the power to all components is turned off at the switchboard BEFORE connecting the DVI/USB repeater.

Note 2: The DVI/USB repeater uses DC power. If your vessel has AC power, a rectifier is required.

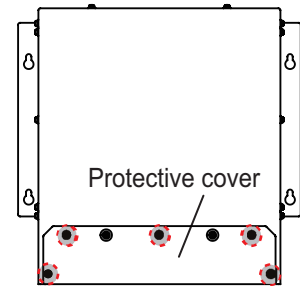

 : Screws for protective cover

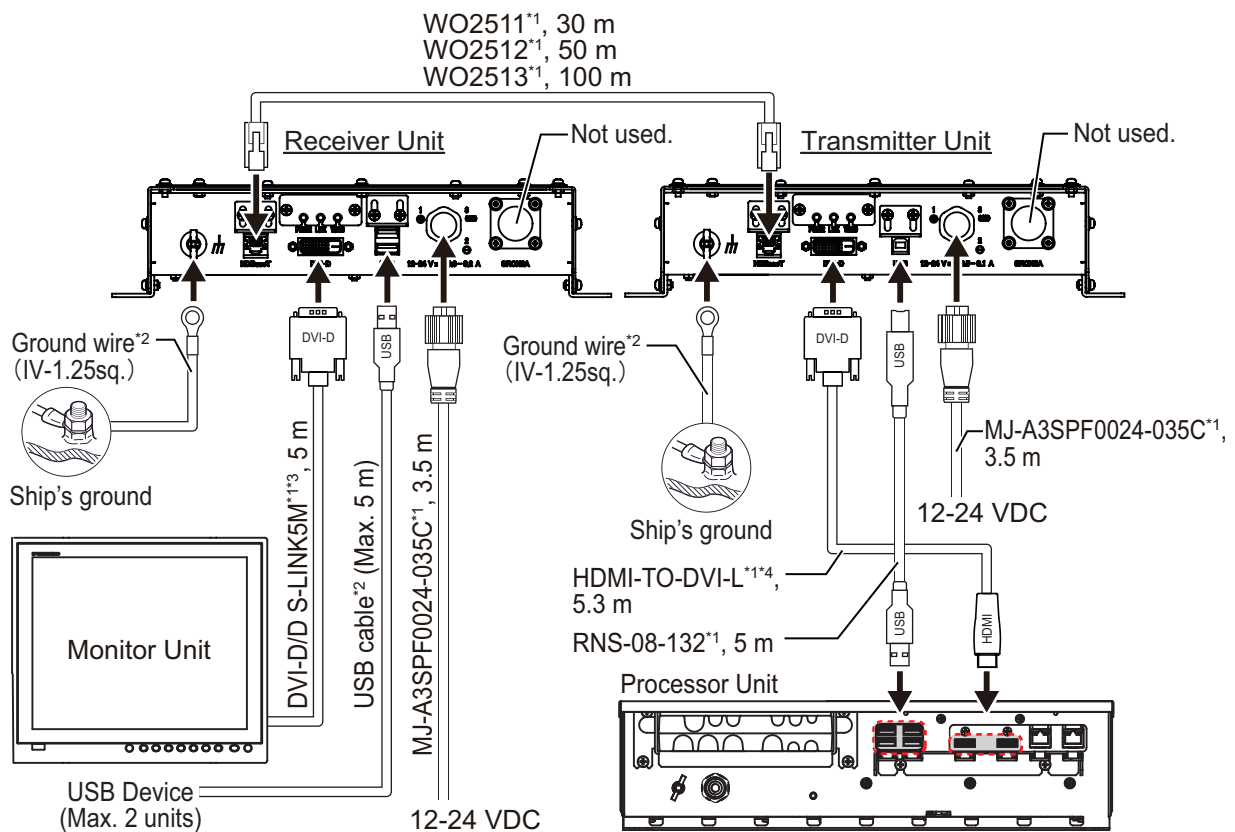

- ^{*1}: Option
- ^{*2}: Local supply
- ^{*3}: Maximum 5 m length
- ^{*4}: Maximum 5.3 m length

The LAN and USB cables must be fastened to the cable clamp, using a cable tie (supplied locally).

After wiring, reattach the protective cover.

Note: The cable clamp for the USB and LAN cables can be adjusted to accommodate the connectors of those cables. See the following figure.

Unfasten the indicated screws to adjust the cable clamp. Refasten the screws to secure the cable clamp after adjustment.

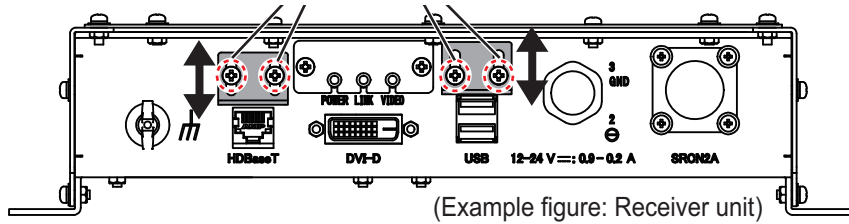

2.7 Input/Output Sentences (NMEA0183)

This equipment can input/output the following sentences:

Sentence	Data	NMEA0183 Version
Input sentences		
GGA	Global positioning system (GPS) fix data	Ver. 1.5/2.0/3.0
GLL	Geographic position - latitude/longitude	Ver. 1.5/2.0/3.0
GNS	GNSS fix data	Ver. 3.0
MTW	Water temperature	Ver. 1.5/2.0/3.0
VHW	Water speed and heading	Ver. 1.5/2.0/3.0
VTG	Course over ground and ground speed	Ver. 1.5/2.0/3.0
ZDA	Time and date	Ver. 1.5/2.0/3.0
GPatt	FURUNO proprietary sentence	-
GPhve	FURUNO proprietary sentence	-
IIDAD	Proprietary sentence of other company	-
IIDBS	Proprietary sentence of other company	-
IIHFB	Proprietary sentence of other company	-
IIMTW	Proprietary sentence of other company	-
IITPC	Proprietary sentence of other company	-
IITPT	Proprietary sentence of other company	-
MPMSD	Proprietary sentence of other company	-
pireq	FURUNO proprietary sentence	-
SDDBS	Proprietary sentence of the other company	-
SDfuz	FURUNO proprietary sentence	-
Output sentences		
DBS	Depth below surface	Ver. 1.5
DBT	Depth below transducer	Ver. 1.5/2.0/3.0
DPT	Depth	Ver. 2.0/3.0
MTW	Water temperature	Ver. 1.5/2.0/3.0
TLL	Target latitude and longitude	Ver. 3.0
SDbhr	FURUNO proprietary sentence	-
SDflg	FURUNO proprietary sentence	-
SDmrk	FURUNO proprietary sentence	-
pidat	FURUNO proprietary sentence	-

3. INITIAL SETTINGS

This chapter covers the initial setup of the equipment.

3.1 How to Set the Language and Measurement Unit

Set the language and measurement unit from the advanced setting menu at installation.

1. Turn the power on.

Open the power button [] cover on the trackball control unit, then press the power button. An audible “beep” indicates the equipment is starting up and the start-up screen appears.

2. Show the InstantAccess bar™ by press the [] button at left-top when the InstantAccess bar is hidden.

To hide the InstantAccess bar, press the [] button or right-click the trackball control on any section of the screen.



3. Select the [Advanced Settings] icon () from the InstantAccess bar to expand the [Advanced Settings] menu bar.

4. Select the [Advanced Settings] icon () from the Menu bar.

The [Advanced Settings] menu window appears.

5. Select [User Interface Settings] from the menu.

The user interface settings appear.

Select this icon to reset the current menu settings to factory default.

Confirm changes and close the menu.

Apply changes. (Menu remains open).

Cancel changes and close the menu.

6. Select the appropriate language from the [Language] item. The setting languages are English (default setting) and Japanese.

7. Select the measurement units.

Item	Meaning	Unit	Default
[Depth]	Water depth	m, ft, fm, ㇇㇇, pb	ft
[Speed]	Ship's speed	kn, km/h, mph	kn

3. INITIAL SETTINGS

Item	Meaning	Unit	Default
[Temperature]	Water temperature	°C, °F	°F
[Fish Size]	Fish length	cm, inch, g, dB	inch

Note: When you change any unit except speed, the following message appears. Press the [Yes] button to close the message and restore all related settings to default.

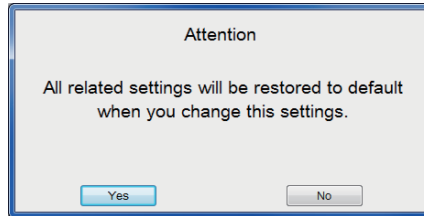



8. Select [OK] to save the current changes and close the menu window.

3.2 How to Set the [Service] Menu

Set the initial parameters for this system from the main monitor.

3.2.1 How to display the [Service] menu

1. Select the [Advanced Settings] icon () from the InstantAccess bar and select the [Advanced Setting] icon () from the expanded menu bar.
2. Select [Service] to expand the service menu. The message "Ask your dealer to change service settings." appears.
3. Press and hold the [OK] button for approx. 10 seconds to open the service advanced menus, [Shared Settings], [Fish Size Setting] and [External Echo Sounder].

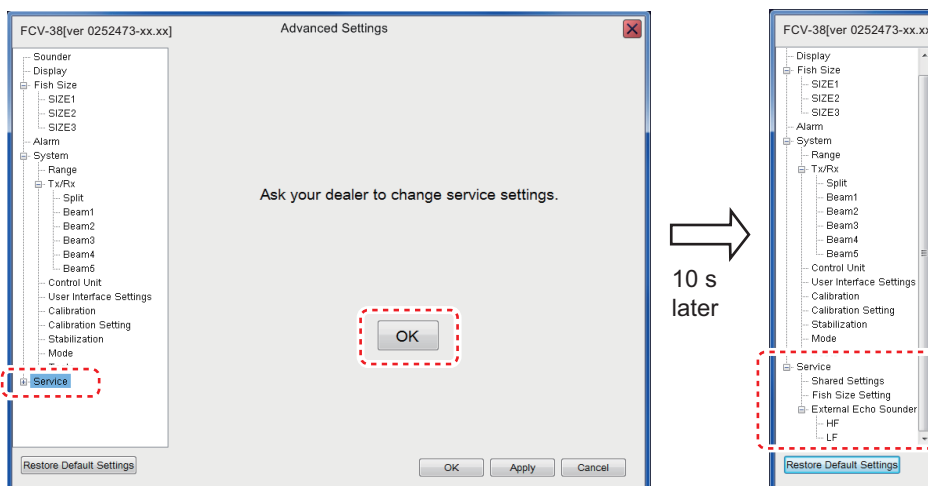

3.2.2 Monitor setting

Set the monitors (main/sub) from the [Service] menu. Select [Shared Settings] on the [Service] menu to show the [Shared Settings] menu.

Item	Setting value	Meaning
[Display Resolution Switching]	[Auto] (default)	Show the resolution which is input from the connected display.
	[Manual]	Select the resolution manually for the following menu [Display Resolution]
[Display Resolution]*	[XGA] (default), [SXGA], [UXGA], [FullHD], [WUXGA]	Select the appropriate resolution for main monitor. Note: This menu is available when [Manual] is selected at [Display Resolution Switching].
[Sub Monitor Display Switching]	[Dual] (default)	The FCV-38 logo is shown on the sub monitor, and the graphs etc. can be moved to the sub monitor from the main monitor.
	[Clone]	The main monitor echo image is shown on the sub monitor.
[Sub Monitor Position]*	[Off] (default), [Left], [Right]	Select the position of sub monitor display in the main monitor display. Note: This menu is available when [Dual] is selected at [Sub Monitor Display Switching].
[Sub Monitor Display Resolution]*	[XGA] (default), [SXGA], [UXGA], [FullHD], [WUXGA]	Select the appropriate resolution for sub monitor. Note: This menu is available when [Manual] is selected at [Display Resolution Switching].

*: The system reboot is required for apply the settings. When you apply the customized settings, the following confirmation message appears. Click the [Yes] button to reboot the system. A buzzer sounds during the system reboot because the communication between the processor unit and the trackball control unit is disconnected temporarily. The buzzer is stopped after completing the system reboot.

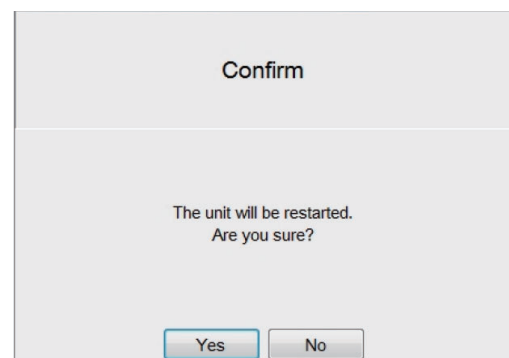

External Fish Finder Window

If an external monitor and an external fish finder are connected, set the [External Fish Finder Window] to [On] to show the independent echo pictures of the external fish finder. The setting should be left [Off] (default) while no external monitor is connected.

- [Off]: The echo pictures for this equipment and external sounder are displayed on main monitor.

3. INITIAL SETTINGS

- [On]: The echo picture for this equipment is displayed on main monitor and the echo picture for external sounder is displayed on sub monitor. To display the echo picture on the sub monitor, select the [Display] icon () from the InstantAccess bar followed by selecting the [External Echo Sounder] icon

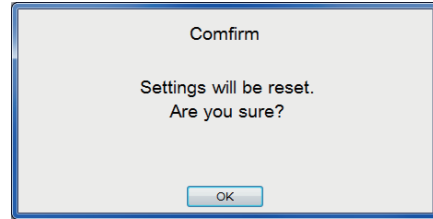

(). The message shown to the above-right appears, select the [OK] button to reset the system.

Note 1: This menu is available when [Dual] is selected at [Sub Monitor Display Switching].

Note 2: The display resolution setting is required when the monitor type is changed.

3.2.3 Date and time setting

Set the date and time on the [Shared Settings] menu.

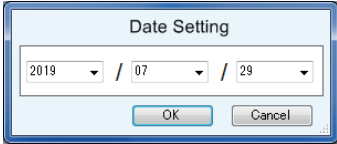
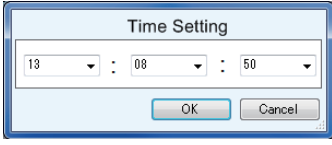
Item	Setting value	Meaning
[Date Auto Adjust]	[Off], [On] (default)	Select [On] to automatically adjust the date and time at system start-up. Select [Off] to manually adjust the date and time as required.
[Date Setting]	YYYY/MM/DD	Enter the appropriate date manually in the box below. Note: This menu is available when [Off] is selected at [Date Auto Adjust]. 
[Time Setting]	hh/mm/ss	Enter the appropriate time manually in the box below. Note: This menu is available when [Off] is selected at [Date Auto Adjust]. 

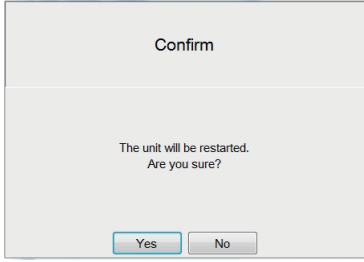
Item	Setting value	Meaning
[Time Zone]	Select the appropriate time zone. Note: System reboot is required to apply the settings. The following confirmation message appears. Click the [Yes] button to reboot the system. A buzzer sounds during the system reboot because the communication between the processor unit and the trackball control unit is disconnected temporarily. The buzzer is stopped after completing the system reboot.	 <p>The dialog box is titled 'Confirm'. It contains the text: 'The unit will be restarted. Are you sure?'. At the bottom, there are two buttons: 'Yes' and 'No'.</p>

3.2.4 KP control setting

Set the KP control signals at [TX Triggering] on the [Shared Settings] menu. The polarities for KP input and output are positive.

Note: External KP levels are follows:

- Input: 5 V to 12 V
- Output: 12 V

Item	Setting value	Meaning	
[TX Triggering]	[In Trigger]	[Off] (default), [On]	Select [On] to input the external KP control.
	[External Trigger Delay]	[0] to [200] (default: [0])	Set the delay for the external KP, 0 to 200 (ms).

3.2.5 Water temperature source setting

Set the water temperature source at [Temp Source] on the [Shared Settings] menu.

Item	Setting value	Meaning
[Temp Source]	[NMEA] (default)	Signal from the connected equipment.
	[External E/S Water Temperature sensor]	Temperature sensor connected to external sounder.
	[External Transducer (HF)]	Temperature sensor in the external sounder's high frequency transducer.
	[External Transducer (LF)]	Temperature sensor in the external sounder's low frequency transducer

3. INITIAL SETTINGS

3.2.6 Transducer setting

You can increase the accuracy of your fish finder by adjusting transducer parameters. Adjust the parameters as follows:

Item	Setting value	Meaning
[Transducer Parameter1]	-100.00 to +100.00 (default: 0.00, step: 0.01)	Set the calibration of source level and receive sensitivity for transducer.
[Transducer Parameter2]	—	Not used
[Transducer Parameter3]	-100.00 to +100.00 (default: 0.00, step: 0.01)	When the Junction Box is used , you can calibrate for cable attenuation. Note: If the optional junction box CV-304-50M is connected to this equipment, this menu setting should be +1.8.

Note: The adjustment must be re-done if the transducer is replaced or the unit factory default settings are restored.

Transducer parameters can be kept for reference on the data sheet stickers attached to the transducer cable (see page 1-8). Write the transducer parameter information on the data sheet. Detach them and attach one on the display unit and one to back cover of the operator's manual.

3.2.7 Other settings

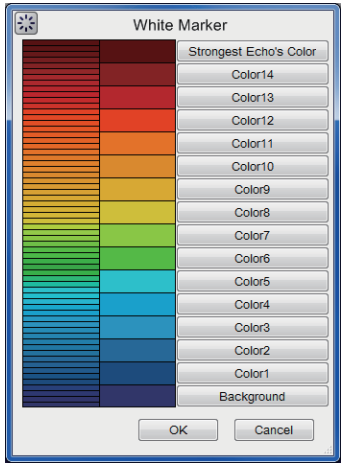

This section covers menu items not explained previously in this manual.

Item	Setting value	Meaning	
[IIMTW Sentence]	[Off] (default), [Water Temp Meter], [ITI Net Sensor]	Select [ITI Net Sensor] if an ITI net sensor is connected. Otherwise, select [Off] or [Water Temp Meter].	
[Random TX]	[Off], [On] (default)	Select [On] to transmit random KP.	
[White Marker]	Displays selected echoes in white color. Select the detailed icon (▶) to show the color selection pop-up window as shown in the figure to the right. Select the echo color to be displayed as white from 16 types, then select [OK]. To cancel all changes, select [Cancel].		
[Bottom Noise Rejector]	[Off], [On] (default)	Select [On] to reject the unwanted bottom echo noise .	
[Step Gain Range]	[Low-Mid]	[0] to [5000] (default: [20], step: 1)	Set distance step (m) between low and mid frequencies.
	[Mid-Hi]	[0] to [5000] (default: [320], step: 1)	Set distance step (m) between mid and high frequencies.

Item		Setting value	Meaning
[Step Gain Calibration]	[Low]	[-50.0] to [2.0] (default: [0.0], step: 0.1)	Set gain increment (dB) at low frequency.
	[Mid]	[-50.0] to [2.0] (default: [-15.5], step: 0.1)	Set gain increment (dB) at mid frequency
	[Hi]	[-50.0] to [2.0] (default: [-31.2], step: 0.1)	Set gain increment (dB) at high frequency
[Processor Unit IP Address]		[1] to [254] (default: [7])	Set the fourth octet of IP address 1 for the processor unit and the transceiver unit.
[Transceiver Unit IP Address]		[1] to [254] (default: [9])	Note 1: The first to third octets are fixed to 172.31.2. Note 2: Each IP address must be unique between units.
[PRC Settings]		Select ► button to show the contents for the signal parameter setting.	
[Update PRC Settings]		Select ► button to show the confirmation message to reset the signal parameter setting. Select [Yes] to reset on the confirmation message.	

3.3 Communication Port Setting

You can set the communication port (NMEA1 to NMEA5) from the [Tests] menu. To select the signals for communication, do the following.

1. Select the [Advanced Settings] icon () from the InstantAccess bar and select the [Advanced Setting] icon () from the expanded menu bar.
2. Select [Tests] from the [System] menu. The [Tests] menu appears on the right-hand side of the window.

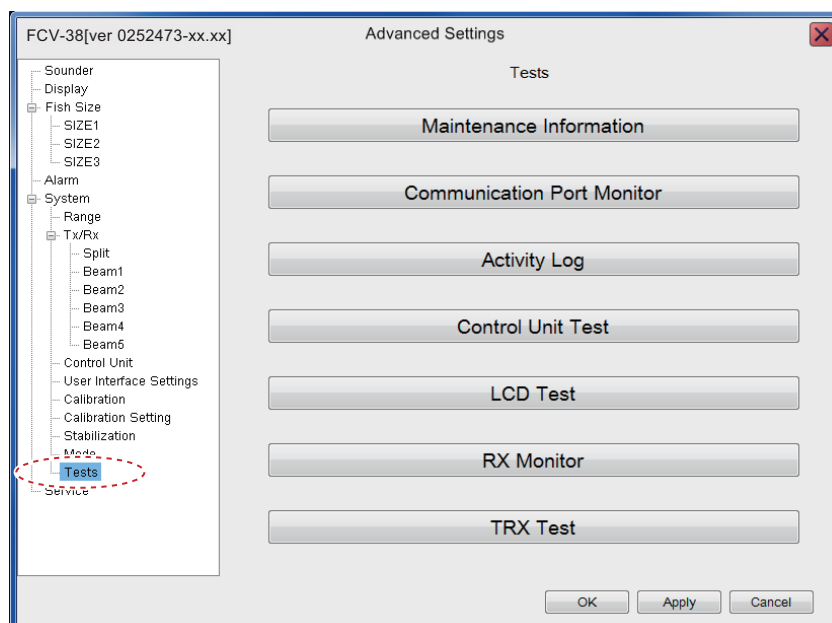

3. INITIAL SETTINGS

3. Select the [Communication Port Monitor] from the [Tests] menu.
The communication port monitor window appears.

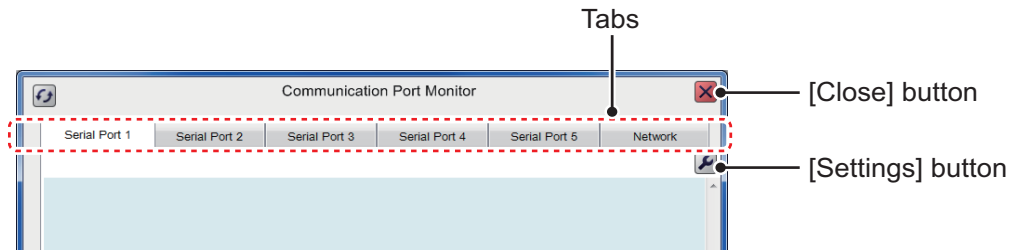

4. Select a port tab ([Serial Port1] to [Serial Port5]) to show the corresponding port.
5. Press the [Settings] button () to show the port setting menu.

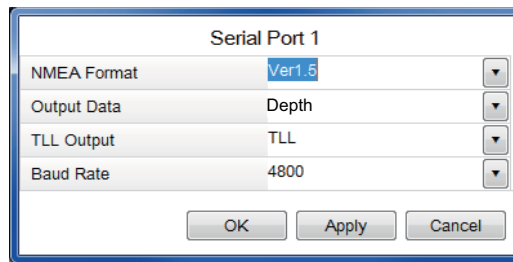

6. Select a NMEA format among Ver 1.5, Ver 2.0 and Ver 3.0.
Note: When the NMEA format is changed, the defaults settings are restored for the items in the same window.
7. Select output data from [Depth], [Temperature] or [Hardness And Roughness].
You can select more than one datum.
8. Select a TLL output data from [TLL], [FURUNO-TLL] or [Off].
 - [TLL]: Shows L/L data output
 - [FURUNO-TLL]: Shows L/L, water temperature and fish size data output
 - [Off]: No output of the longitude/latitude data.**Note:** These output data require appropriate external data input.
9. Select a baud rate from 600, 4800 or 38400 bps at [Baud Rate], then click the [OK] button to close the menu.
Note: Select [38400] bps when the [TLL Output] is set to [FURUNO-TLL]. [4800] or [600] bps may slow the transmission of sentences.
10. Push the [OK] button to close the port setting menu.
11. Set the parameters for other port tabs referring to this procedure's steps 4 to 10.
12. Press the [Close] button to close the [Communication Port Monitor] window.

Communication port monitor

The serial signal monitor is available for each port.

- Serial Port 1: NMEA1 port on processor unit.
- Serial Port 2: NMEA2 port on processor unit.
- Serial Port 3: NMEA3 port on processor unit.
- Serial Port 4: NMEA4 port on processor unit.
- Network: Network (LAN) port on processor unit.

Select the port tab from the communication port monitor window, then press the [Update] button to display the received data for selected port.

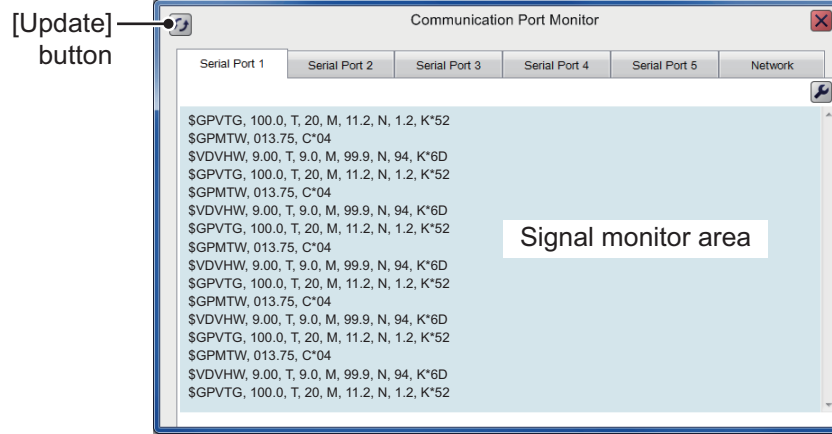



3.4 External Echo Sounder Setting

To set the external echo sounder, two methods are available: from the main monitor or the sub monitor. If you have a sub monitor and [External Fish Finder Window] (see page 3-3) is set to [On], the parameters are set from the sub monitor's menu.

3.4.1 [External Fish Finder Window] setting: Off

The compatible external echo sounder (fish finder) is a DFF3. Set the transducer parameters from the main monitor as follows:

1. Select the [Advanced Settings] icon () from the InstantAccess bar, then select the [Advanced Settings] icon () from the menu bar.
The [Advanced Settings] menu windows appears.
2. Select [Service] to expand the service menu.
The message "Ask your dealer to change service settings." appears.
3. Press and hold the [OK] button for approximately ten seconds to open the service advanced menu.
4. Select the "External Echo Sounder" from the [Service] menu.

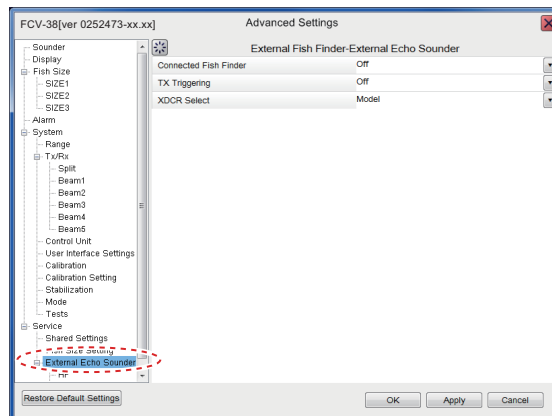

5. Select [DFF3] from the [Connected Fish Finder] menu.
The message appears to reset the settings. Press the [OK] button to close the message.

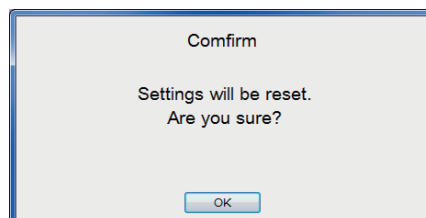

6. Select the [TX Triggering] to [On] to enable KP control with the DFF3.
Note: The main transceiver's TX trigger setting should be [Off] while this external TX trigger is set [On].

7. Set the [XDCR Select] to [Model] or [Manual] to set the transducer in use.

- [Model]: The selectable models are shown below.

- | | | | |
|--------------|------------|-------------|-------------|
| • 28F-8 | • 50B-12 | • 88B-10 | • 28BL-6HR |
| • 28F-18 | • 50BL-12 | • 88F-126H | • 28BL-12HR |
| • 28F-24H | • 50F-24H | • 100B-10R | • 38BL-9HR |
| • 50B-6/6B | • 50BL-24H | • 150B-12H | • 38BL-15HR |
| • 50B-9/9B | • 68F-8H | • 200B-5S | • 50BL-12HR |
| • 50/200-1ST | • 68F-30H | • 200B-8/8B | • 50BL-24HR |
| • 50/200-1T | • 88B-8 | • 200B-12H | • 82B-35R |

- [Manual]: For other transducer settings manually.

When [Manual] is selected

1) Select the [HF] (High Frequency) or [LF] (Low Frequency) among [External Echo Sounder] in the [Service] menu to set the transducer parameters.

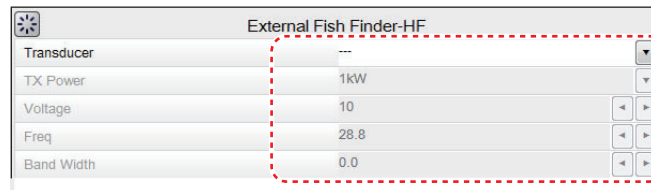

Available when [XDCR Select] is set to [Manual].

For [HF]



- 2) Select the output power of the transducer connected to [TX Power], from among 1kW, 2kW, 3kW.
- 3) Select [Voltage], then set TX voltage of the transducer.
- 4) Select [Freq], then set the frequency of the transducer.
- 5) Select [Band Width], then set the band width of the transducer.

8. Click the [OK] button.

3.4.2 [External Fish Finder Window] setting: On

The external echo sounder (fish finder) settings are available on sub monitor window when the sub monitor is connected. The following procedure covers how to set the transducer's parameters from the sub monitor. The procedure assumes that [External Fish Finder] (see page 3-3) has already been set to [On].

Set the transducer's parameters from sub monitor window as belows. Suppose the sub monitor is installed and the [External Fish Finder Window] (see page 3-3) is set to [On] already.

1. Select the [Windows] icon () from the InstantAccess bar, and press the [Sub monitor] icon () to display the echo window of external fish finder on the sub monitor.
2. Right-click on the sub monitor to show the [Advanced settings] menu for external sounder setting.
3. Select [Service] to expand the service menu.
The message "Ask your dealer to change service settings." appears.
4. Press and hold the [OK] button for approximately ten seconds.
The advanced service menu for external sounder appears.



3. INITIAL SETTINGS

5. Select [Shared Settings] to open the [Shared Settings] menu.
6. Select [On] at [TX Triggering] to enable KP control with the DFF3.
Note: The main transceiver's [TX Triggering] setting should be [Off] while this external TX trigger is set [On].
7. Select [Model] at [XDCR Select].
 Set the model, referring to the procedure at paragraph 3.4.1
8. Select [OK] to close the menu.

3.5 Calibration Setting

The calibration menu allows you to calibrate various settings. You can calibrate the main system's transducer and the external sounder's transducer.

3.5.1 Calibration for main system transducer

1. Select the [Advanced Settings] icon () from the InstantAccess bar and select the [Advanced Setting] icon () from the expanded menu bar.
2. Select [Calibration] from the [System] menu.
 The [Calibration] menu appears.

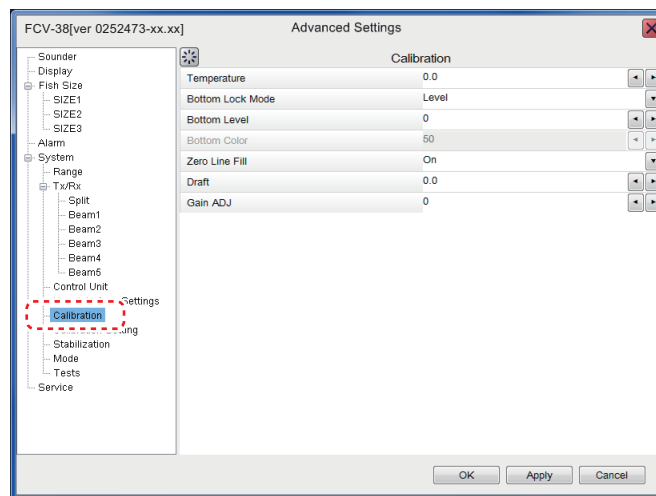

3. Set the calibration parameters referring to the table below:

Item	Setting values	Meaning
[Temperature]	°F: -35.0 to 35.0 °C: -20.0 to 20.0 (default: 0.0)	The water temperature indication is corrected. For example, if the actual temperature is 2°F higher than the temperature displayed on screen, set the offset to [+2°F].

Item	Setting values	Meaning
[Bottom Lock Mode]	[Level], [Color]	Set how the bottom edge is determined, by signal level or display color. <ul style="list-style-type: none"> • [Level]: Determine the bottom edge by signal level. When the method is [Color], bottom fish may be hidden in the bottom edge. With [Level] the shape of the bottom echo may change depending on the bottom contour of the bottom. • [Color]: Determine the bottom edge by display color. When bottom fish are well separated from the bottom, the bottom is displayed with a straight line, making discrimination of bottom fish easier. However, the bottom presentation may change depending on gain setting. When set to Color, select the color (0-63) to be judged as the bottom echo.
[Bottom level]	[-40] to [40] (default: [0])	Set the strength at which an echo is determined to be the bottom. If the level is too low, however, it may be difficult to distinguish bottom fish from the bottom echo.
[Bottom Color]	[0] to [63] (default: [50])	Set the color for the bottom.
[Zero Line Fill]	[Off], [On] (default)	Turn off to see fish echoes within 1 m from the surface.
[Draft]	[m]: -9.0 to 30.4 [ft]: -30.0 to 99.9 [fm]: -5.0 to 16.6 [HR]: -6.0 to -20.1 [pb]: -6.0 to -18.8 (default: 0.0)	The default depth display shows the distance from the transducer. If you would rather show the distance from the sea surface, set your ship's draft. The draft line for HF and LF can be set respectively.
[Gain ADJ]	[-50] to [50] (default: [0])	If the gain is too high or too low, or the gain for the low and high frequencies appears unbalanced, you can compensate it here.

4. Select [OK] to close the menu.

3.5.2 Calibration for external system transducer

The calibration procedure for external echo sounder is different from the FCV-2100. There are two methods, depending on equipment configuration.

External Echo Sounder mode is 'Off'

1. Select the [Advanced Settings] icon () from the InstantAccess bar, and select the [Advanced Setting] icon () from the expanded menu bar.

3. INITIAL SETTINGS

2. Select [Calibration] from the [External Echo Sounder] menu list.
The [Calibration] menu appears.

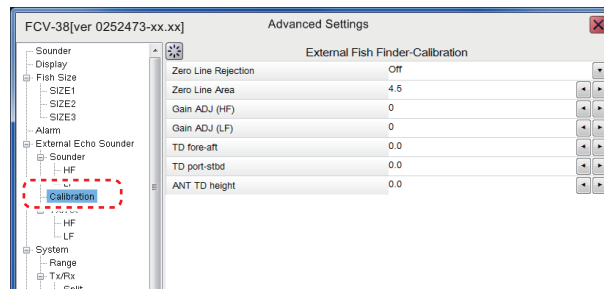

3. Set the calibration parameters from the list.

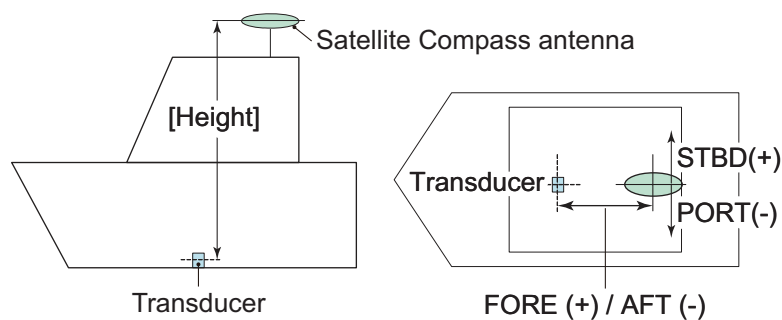

Item	Setting values	Meaning
[Zero Line Rejection]	[Off], [On] (default)	Turn the zero line (transmission line) on or off.
[Zero Line Area]	[m]: 1.4 to 3.0 [ft]: 4.5 to 9.8 [fm]: 0.7 to 1.6 [HR]: 0.9 to 2.0 [pb]: 0.8 to 1.8 (The minimum value is default.)	Adjusts the transmission line. Refer the figure below this table.
[Gain ADJ (HF)]	[-50] to [50] (default: [0])	Set the gain for high frequency of the Satellite Compass.
[Gain ADJ (LF)]	[-50] to [50] (default: [0])	Set the gain for low frequency of the Satellite Compass.
[TD fore-aft]	[-100.0] to [100.0] (default: [0.0])	Fore-aft distance (m) from antenna to transducer. Enter a positive value for a fore-side transducer.
[TD port-stbd]	[-100.0] to [100.0] (default: [0.0])	Port-starboard distance (m) from antenna to transducer. Enter a positive value for a starboard-side transducer.
[ANT TD height]	[0.0] to [100.0] (default: [0.0])	Vertical distance (m) between the antenna and the transducer.



4. Select [OK] to close the menu.

External Echo Sounder mode is 'On'

When an echo sounder is selected at [Connected Fish Finder] in the [External Echo Sounder] menu, do the following settings for the external echo sounder.

1. Select the [Display] icon () from the InstantAccess bar, and select the [External Sounder] icon () from the expanded menu bar.
The external echo picture is displayed on the sub monitor.

2. Move the cursor onto the sub monitor and right-click on the screen.
The setting menu for external echo sounder appears.
3. Select the [Calibration] menu from the [System] menu.
The [Calibration] menu appears.
4. Set the calibration parameters referring to the table below:

Item	Setting values	Meaning														
[Zero Line Rejection]	[Off], [On] (default)	Turn the zero line (transmission line) on or off.														
[Zero Line Area]	[m]: 1.4 to 3.0 [ft]: 4.5 to 9.8 [fm]: 0.7 to 1.6 [HR]: 0.9 to 2.0 [pb]: 0.8 to 1.8 (The minimum value is default.)	Adjusts the transmission line.														
[Draft]	[m]: -9.0 to 30.4 [ft]: -30.0 to 99.9 [fm]: 0.7 to 1.6 [HR]: 0.9 to 2.0 [pb]: 0.8 to 1.8 (default: 0.0)	The default depth display shows the distance from the transducer.														
[Fish Size]	[-80] to [100] (default: [0])	Compensate for incorrect fish size indications (%). <table border="1" data-bbox="954 1003 1385 1238"> <thead> <tr> <th>Setting value (%)</th> <th>Adjustment</th> </tr> </thead> <tbody> <tr> <td>-80</td> <td>1/5</td> </tr> <tr> <td>-75</td> <td>1/4</td> </tr> <tr> <td>-65</td> <td>1/3</td> </tr> <tr> <td>-50</td> <td>1/2</td> </tr> <tr> <td>+50</td> <td>x1.5</td> </tr> <tr> <td>+100</td> <td>x2</td> </tr> </tbody> </table>	Setting value (%)	Adjustment	-80	1/5	-75	1/4	-65	1/3	-50	1/2	+50	x1.5	+100	x2
Setting value (%)	Adjustment															
-80	1/5															
-75	1/4															
-65	1/3															
-50	1/2															
+50	x1.5															
+100	x2															
[Sound Speed]	[200.0] to [2000.0] (default: [1500])	Calibration for speed of sound (m/s).														

5. Set the calibration parameters for bottom level and gain adjust from the [HF] or [LF] menu under the [Calibration] menu.

Item	Setting values	Meaning
[Bottom Level]	[-40] to [40] (default: [0])	Set the strength at which an echo is determined to be the bottom. Adjust this setting carefully as an excessively high setting may hide fish located near the seabed.
[Gain ADJ]	[-50] to [50] (default: [0])	Adjust this setting if the gain is too high or too low, or the gain for the low and high frequencies appears unbalanced.

6. Select [OK] to close the menu.

3.6 Stabilization Setting



The [Stabilization] menu compensates for the effects of heaving, and requires a Satellite Compass.

Note 1: The menu is not available when there is no data from the Satellite Compass.

Note 2: This function is NOT available when [In Trigger] in [Shared Settings] is set to [On].

3.6.1 Stabilization for main system transducer

Set the stabilization menu for main system and external system transducers when the [External sounder] is set [Off].

1. Select the [Advanced Settings] icon () from the InstantAccess bar, and select the [Advanced Setting] icon () from the expanded menu bar.
2. Select [Stabilization] menu from the [System] menu. The [Stabilization] menu appears.

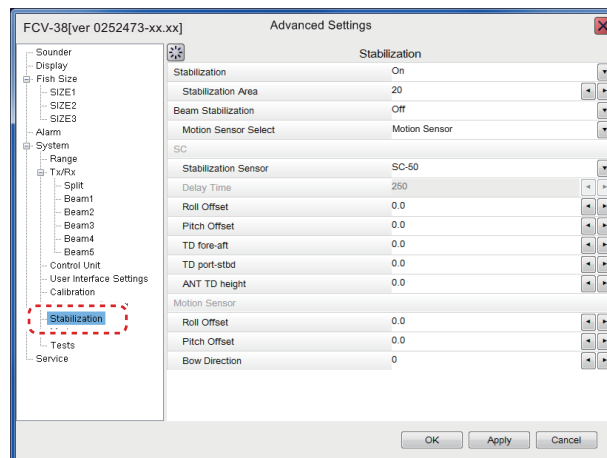

3. Set the calibration parameters referring to the table below:

Item	Setting values	Meaning
[Stabilization]	[Off] (default), [On]	Set to [On] to enable the stabilization mode. Turn this function on when seas are rough, to get stable pictures. When heaving stabilization is turned on, the symbol () appears at the [Advance] header on the screen.
[Stabilization Area]	[0] to [20] (default: [20])	Adjusts the stabilization line (m).
[Beam Stabilization]	[Off] (default), [On]	Set to [On] to enable the beam stabilization.

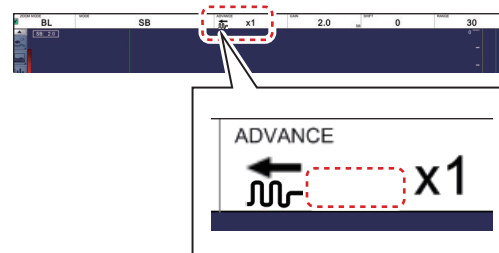

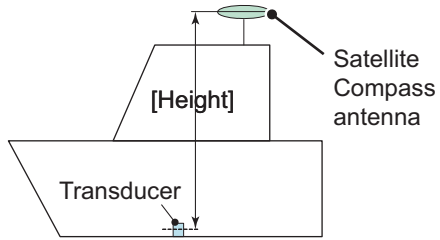
Item	Setting values	Meaning	
[Motion Sensor Select]	[Motion Sensor] (default), [SC]	Select the internal sensor or SC (Satellite Compass) for stabilization.	
[Stabilization Sensor]	[Manual], [SC-50] (default), [SC-110], [SC-30], [SC-70], [SC-130], [SC-33], [GS-100], [SCX-21]	Select the model of Satellite Compass when [Motion sensor Select] is set to [SC].	
[Delay Time]	[0] to [300] (default: [250])	Set the delay time (ms). This menu is available when [Stabilization Sensor] is set to [Manual].	
[Roll Offset]	[-10.0] to [10.0] (default: [0.0])	Compensate the roll angle error (°C) of the motion sensor. Set positive values when the starboard is up.	Note: The satellite compass has its own roll and pitch corrections. Enter compensations here or at the satellite compass; do not compensate at both.
[Pitch Offset]	[-10.0] to [10.0] (default: [0.0])	Compensate the pitch angle error (°C) of the motion sensor. Set positive values when the stern is up.	
[TD fore-aft]	[-100.0] to [100.0] (default: [0.0])	Fore-aft distance (m) from antenna to transducer. Enter a positive value for a fore-side transducer.	
[TD port-stbd]	[-100.0] to [100.0] (default: [0.0])	Port-starboard distance (m) from antenna to transducer. Enter a positive value for a starboard-side transducer.	
[ANT TD height]	[0.0] to [100.0] (default: [0.0])	Vertical distance (m) between the antenna and the transducer.	
			
For [Motion Sensor] selecting at [Motion Sensor Select];			
[Roll Offset]	[-10.0] to [10.0] (default: [0.0])	Set the stabilization angle (°C) for roll. If the motion sensor in the processor unit is tilted upwards to the left, set a negative value.	
[Pitch Offset]	[-10.0] to [10.0] (default: [0.0])	Set the stabilization angle (°C) for pitch. If the motion sensor in the processor unit is tilted upwards to the bow, set a positive value.	
[Bow Direction]	[0] to [359] (default: [0])	If the motion sensor in the transceiver unit is not mounted with the front panel facing directly to port, the motion sensor is not oriented towards the bow. In this case, correct (offset) the installation angle here. For example, if the front panel is facing the bow and the motion sensor is facing starboard, set a correction of 90 (degrees). (See "Mounting Consideration" on page 1-3 for the bow direction of the transceiver unit.)	

Note: Calibrated settings should be recorded on the NOTE label on the front panel of the transceiver unit.

3. INITIAL SETTINGS

4. Select the [OK] to close the menu.

Note: For the heaving feature, set the SC-30/50/110 Satellite Compass output as follows. Refer to respective operator's manual for setting details.

- Sentence: ATT (GPatt), HVE(GPhve)
- Baud rate: 38400 bps
- Cycle: 25 ms
- Format (SC-50/110 only): IEC Ed.1

3.6.2 Stabilization for external sounder transducer

Set the stabilization menu for external system transducers when [External sounder] is set [On].

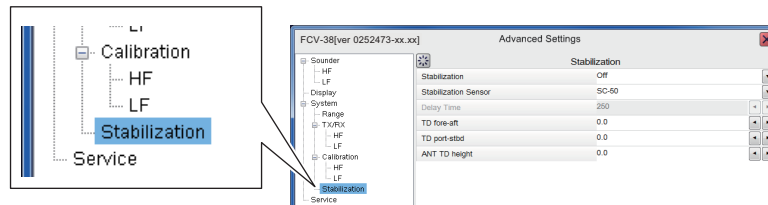

1. Move the cursor onto the sub monitor and right-click on the screen. The setting menu for external sounder appears.
2. Select [Stabilization] from the list on menu. The [Stabilization] menu appears.



3. Set the stabilization parameters refer to step 3 on section 3.6.1.

3.7 How to Take a Still Image of the RX Monitor

After the installation, take a still image of the RX monitor screen in a harbor test. The still image of the RX monitor screen is used for checking the equipment in maintenance.

1. Click the [Settings] icon () from the InstantAccess bar, then click the [Advanced Settings] icon ().
2. Select the [Tests] from the menu on the left-hand side of the window. The [Tests] menu appears on the right-hand side of the window.
3. Select the [Rx Monitor] from the [Tests] menu. The RX monitor screen appears.



4. Select the beam to be displayed at the drop-down box on the screen.
 - [SB]: Split beam
 - [B1] to [B5]: Beam 1 to Beam 5
 - [Rx Test]: Receiving test
5. Press the wheel on the trackball to take a still image.
6. Click the [Close] button to close the RX monitor screen.
7. Press and hold the scrollwheel on the trackball control unit to open the replay screen, then confirm that the still image that of the RX monitor screen is saved correctly.

3.8 Reset to Default Setting

To reset all customized settings for advanced setting menus and external sounder setting menus to their default settings. The external echo sounder setting should be reset before the reset of main system setting. Do the following procedure.

Note: Customized settings cannot be restored. If necessary, write the settings down.

3. INITIAL SETTINGS

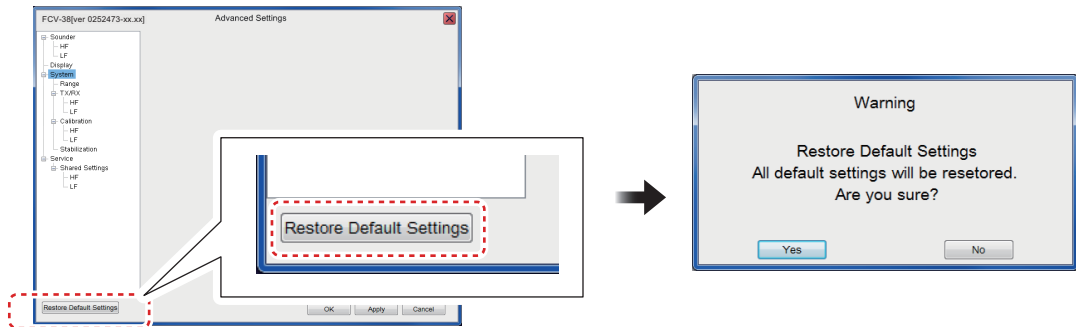

Reset the external sounder settings

1. Move the cursor to the external echo picture on sub monitor, and right-click on the screen.
2. Select [Service] from the menu, then press and hold the [OK] button for approximately ten seconds. The [Service] menu is expanded.
3. Select [Restore Default Settings] at the left bottom corner of the window. The message window appears as shown below.



4. Select [Yes] to restart the system.

Reset the main system advanced settings

1. Select the [Advanced Settings] icon () from the InstantAccess bar, and select the [Advanced Settings] icon () from the expanded menu bar.
2. Select [Service] from the menu and press and hold the [OK] button for approximately ten seconds. The [Service] menu is expanded.
3. Select [Restore Default Settings] at the left bottom corner of the window. The message window shown above appears.
4. Select [Yes] to restart the system.

3.9 Retrofit from FCV-30

If the transceiver unit of the FCV-30 is connected to the processor unit of the FCV-38, the IP address of the FCV-30 must be changed. To change the IP address, the IP address changing tool is required.

3.9.1 Required Tools and Device

- PC: Windows® 10 (64 bit)
- upip.exe file: IP address changing tool. Install it on a PC (It can be installed on the Desktop). For this tool, contact your dealer.
- LAN cable

3.9.2 Preparations

1. Select [System]→[Communication]→[Network] from the menu and check the IP address of the FCV-30 transceiver unit.
2. Change the IP address of the PC to an IP address that can connect to the transceiver unit of the FCV-30. Only change the last octet of the IP address confirmed in step 1. (For example, if the IP address of the FCV-30 transceiver unit is "192.168.2.9", set the IP address of the PC to "192.168.2.100".) The default IP address of the FCV-30 transceiver unit is "192.168.2.9".

3.9.3 How to change the IP address

For a PC using Windows[®] 10, set the IP address as follows.

1. Click the Windows[®] mark at the bottom left of the screen, and then select [Windows System Tools]→[Control Panel].
2. Click [Network and Sharing Center].
3. Click [Change adapter settings].
4. Right-click [Wi-Fi] or [Ethernet], and then select [Properties].
5. Select [Internet Protocol Version 4 (TCP/IP v4)], and then click [Properties].
6. Select [Use the following IP address:], change the IP address, and then click [OK].

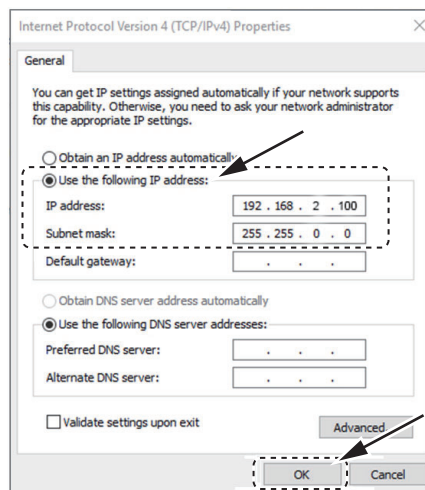

7. Reboot the PC.

3.9.4 How to use the IP address changing tool

1. Connect the PC to the FCV-30 transceiver unit with a LAN cable.
2. Start the IP address changing tool on the PC. The PC receives the IP address from the transceiver unit automatically, and then displays the following windows.
Note: If it fails to receive the IP address, check the IP address of the PC and the LAN connection for errors.

3. INITIAL SETTINGS

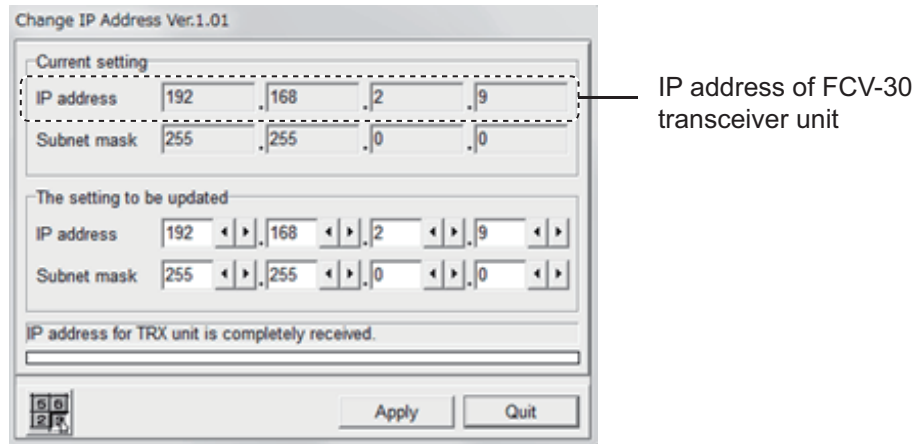

3. Change to the IP address of the FCV-38 as shown in the figure below. The default IP address of the FCV-38 is "172.31.2.9". If the IP address is not changed from the default, enter the default value, and then click [Apply].

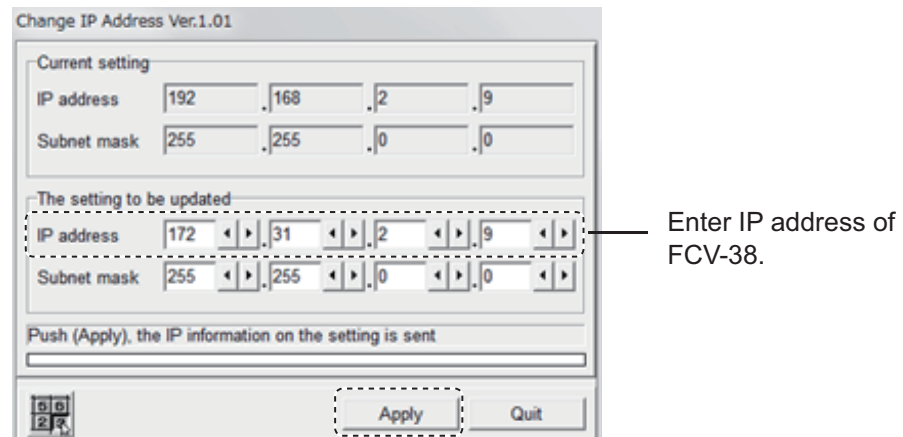

4. When the IP address is changed properly, the message "IP setting is completed." appears above the progress bar. Click [Quit] to quit the tool.
 5. The following message appears. Click [OK].
- Note:** You do not have to change the Subnet mask.

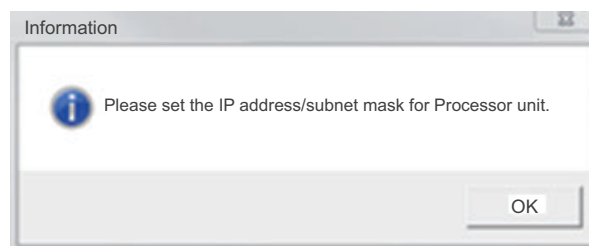

3.9.5 How to check the connection after changing the IP address

Check if the IP address setting of the FCV-30 transceiver unit is shown on the [Transceiver Unit IP Address] setting of the FCV-38 processor unit correctly, before connecting the FCV-30 transceiver unit to the FCV-38 processor unit. The following figure shows "9" at [Transceiver Unit IP Address], which means that the IP address is "172.31.2.9."

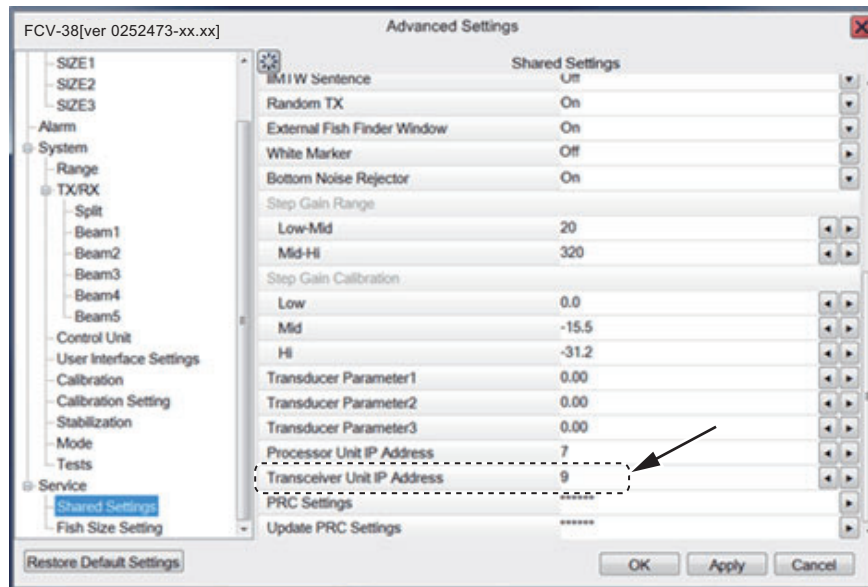

Remove the LAN cable from the FCV-30 transceiver unit, and then connect it to the FCV-38 processor unit. If echoes can be scrolled between the FCV-38 processor unit and the FCV-30 transceiver unit, the setting is correct.

Note: If system error "T01" is shown, the connection is wrong. Check the [Transceiver Unit IP Address] setting of the FCV-38 processor unit and the IP address set in the transceiver unit.

3.9.6 How to change the future IP address

If you change again the IP address of the FCV-30 transceiver unit while using it normally after changing the IP address properly, follow the procedure shown below.

- If connecting the FCV-30 transceiver unit to the **FCV-38** processor unit, you can change the IP address using the processor unit itself. The IP address changing tool is not required.
- If connecting the FCV-30 transceiver unit to the **FCV-30** processor unit, use the IP address changing tool to change the IP address.

3. INITIAL SETTINGS

This page is intentionally left blank.

APPENDIX 1 JIS CABLE GUIDE

Cables listed in the manual are usually shown as Japanese Industrial Standard (JIS). Use the following guide to locate an equivalent cable locally.

JIS cable names may have up to 6 alphabetical characters, followed by a dash and a numerical value (example: DPYC-2.5).

For core types D and T, the numerical designation indicates the *cross-sectional Area (mm²)* of the core wire(s) in the cable.

For core types M and TT, the numerical designation indicates the *number of core wires* in the cable.

1. Core Type

D: Double core power line

T: Triple core power line

M: Multi core

TT: Twisted pair communications
(1Q=quad cable)

2. Insulation Type

P: Ethylene Propylene Rubber

3. Sheath Type

Y: PVC (Vinyl)

4. Armor Type

C: Steel

5. Sheath Type

Y: Anticorrosive vinyl sheath

6. Shielding Type

SLA: All cores in one shield, plastic tape w/aluminum tape

-SLA: Individually shielded cores, plastic tape w/aluminum tape



EX: ^{1 2 3 4 5 6} TTYCYSLA - 4
 Designation type — # of twisted pairs

EX: ^{1 2 3 4} MPYC - 4
 Designation type — # of cores

The following reference table lists gives the measurements of JIS cables commonly used with Furuno products:

Type	Core Area	Core Diameter	Cable Diameter	Type	Core Area	Core Diameter	Cable Diameter
DPYC-1.5	1.5mm ²	1.56mm	11.7mm	TTYCSLA-1	0.75mm ²	1.11mm	9.4mm
DPYC-2.5	2.5mm ²	2.01mm	12.8mm	TTYCSLA-1T	0.75mm ²	1.11mm	10.1mm
DPYC-4	4.0mm ²	2.55mm	13.9mm	TTYCSLA-1Q	0.75mm ²	1.11mm	10.8mm
DPYC-6	6.0mm ²	3.12mm	15.2mm	TTYCSLA-4	0.75mm ²	1.11mm	15.7mm
DPYC-10	10.0mm ²	4.05mm	17.1mm	TTYCY-1	0.75mm ²	1.11mm	11.0mm
DPYCY-1.5	1.5mm ²	1.56mm	13.7mm	TTYCY-1T	0.75mm ²	1.11mm	11.7mm
DPYCY-2.5	2.5mm ²	2.01mm	14.8mm	TTYCY-1Q	0.75mm ²	1.11mm	12.6mm
DPYCY-4	4.0mm ²	2.55mm	15.9mm	TTYCY-4	0.75mm ²	1.11mm	17.7mm
MPYC-2	1.0mm ²	1.29mm	10.0mm	TTYCY-4SLA	0.75mm ²	1.11mm	19.5mm
MPYC-4	1.0mm ²	1.29mm	11.2mm	TTYCYSLA-1	0.75mm ²	1.11mm	11.2mm
MPYC-7	1.0mm ²	1.29mm	13.2mm	TTYCYSLA-4	0.75mm ²	1.11mm	17.9mm
MPYC-12	1.0mm ²	1.29mm	16.8mm				
TPYC-1.5	1.5mm ²	1.56mm	12.5mm				
TPYC-2.5	2.5mm ²	2.01mm	13.5mm				
TPYC-4	4.0mm ²	2.55mm	14.7mm				
TPYCY-1.5	1.5mm ²	1.56mm	14.5mm				
TPYCY-2.5	2.5mm ²	2.01mm	15.5mm				
TPYCY-4	4.0mm ²	2.55mm	16.9mm				

PACKING LIST

02GU-X-9851 -0 1/1

CV-380*

A-1

NAME	UNIT	OUTLINE	DESCRIPTION/CODE No.	Q'TY
ユニット	UNIT			
制御部 PROCESSOR UNIT			CV-380 000-037-343-00	1
予備品	SPARE PARTS			
予備品 SPARE PARTS			SP02-06001 001-569-280-00	1
工事材料	INSTALLATION MATERIALS			
ケーブル組品MJ CABLE ASSY.			MJ-A3SPF0018-050ZC 000-154-025-10	1
工事材料 INSTALLATION MATERIALS			CP10-09701 001-538-140-00	1
図書	DOCUMENT			
ヒューズ交換要領 FUSE REPLACEMENT GUIDE			C12-01903* 000-197-190-1*	1
取扱説明書 OPERATOR'S MANUAL			OM*-23920 000-197-013-1**	1
装備要領書 INSTALLATION MANUAL			IM*-23920 000-197-015-1**	1

コード番号末尾の[*]**は、選択品の代表コードを表します。
CODE NUMBER ENDING WITH "*"** INDICATES THE CODE NUMBER OF REPRESENTATIVE MATERIAL.

(略図の寸法は、参考値です。DIMENSIONS IN DRAWING FOR REFERENCE ONLY.)

C2392-Z01-A

PACKING LIST

02GU-X-9852 -0 1/1

CV-382

A-2

NAME	UNIT	OUTLINE	DESCRIPTION/CODE No.	Q'TY
ユニット	UNIT			
送受信装置 TRANSCEIVER UNIT			CV-382 000-037-345-00	1
予備品	SPARE PARTS			
予備品 SPARE PARTS			SP03-17661 001-249-760-00	1
工事材料	INSTALLATION MATERIALS			
工事材料 INSTALLATION MATERIALS			CP02-09801 001-581-570-00	1

(略図の寸法は、参考値です。DIMENSIONS IN DRAWING FOR REFERENCE ONLY.)

C2392-Z02-A

PACKING LIST

24AL-X-9881 -0 1/1

RCU-026/-HK

A-3

NAME	UNIT	OUTLINE	DESCRIPTION/CODE No.	Q'TY
ユニット	UNIT			
トラックボール操作部 TRACKBALL CONTROL UNIT			RCU-026/-HK 000-027-666-00 **	1
付属品	ACCESSORIES			
付属品 ACCESSORIES			FP24-00801 001-418-410-00	1
工事材料	INSTALLATION MATERIALS			
ケーブル組品(M)USB CABLE ASSEMBLY			TS-20-071-1 L=5000 000-176-700-11	1
工事材料 INSTALLATION MATERIALS			CP24-02301 001-418-400-00	1

コード番号末尾の[*]**は、選択品の代表コードを表します。
CODE NUMBER ENDING WITH "*"** INDICATES THE CODE NUMBER OF REPRESENTATIVE MATERIAL.

型式コード番号が2段の場合、下段より上段に代わる過渡期品であり、どちらが入っています。なお、品質は変わりません。
TWO TYPES AND CODES MAY BE LISTED FOR AN ITEM. THE LOWER PRODUCT MAY BE SHIPPED IN PLACE OF THE UPPER PRODUCT. QUALITY IS THE SAME.

(略図の寸法は、参考値です。DIMENSIONS IN DRAWING FOR REFERENCE ONLY.)

CN

C4473-Z33-A

PACKING LIST

02FX-X-9857 -0 1/1

CV-303

A-4

NAME	UNIT	OUTLINE	DESCRIPTION/CODE No.	Q'TY
ユニット	UNIT			
送変波器 TRANSDUCER			CV-303 *ROHS* 000-037-715-00	1
図書	DOCUMENT			
取扱注意書 HANDLING NOTE			C22-00403* 000-151-838-1*	1

(略図の寸法は、参考値です。DIMENSIONS IN DRAWING FOR REFERENCE ONLY.)

C2373-Z07-A

PACKING LIST
TFB-1600

02FX-X-9856 -0 1/1
A-5

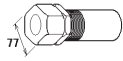
NAME	UNIT	OUTLINE	DESCRIPTION/CODE No.	Q'TY
ワグパイプ THRU-HULL PIPE			TFB-1600 000-012-539	1

(略図の寸法は、参考値です。 DIMENSIONS IN DRAWING FOR REFERENCE ONLY.)

C2373-Z06-A

FURUNO

A-6

CODE NO.	001-538-140-00	10DA-X-9402 -0
TYPE	CP10-09701	1/1

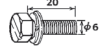
工事材料表		INSTALLATION MATERIALS		数量 Q'TY	用途/備考 REMARKS
番号 NO.	名称 NAME	略図 OUTLINE	型名/規格 DESCRIPTIONS	数量 Q'TY	用途/備考 REMARKS
1	ケーブルタイ CABLE TIE		CV-150N CODE NO. 000-162-186-10	8	
2	六角穴付き ねじ HEX HEAD SLOT BOLT-B WASHER		M6X20 SUS304 CODE NO. 000-162-948-10	4	

(略図の寸法は、参考値です。 DIMENSIONS IN DRAWING FOR REFERENCE ONLY.)

FURUNO ELECTRIC CO., LTD.

C1363-M01-A

FURUNO

A-7

CODE NO.	001-581-570-00	02BU-X-9401 -0
TYPE	CP02-09801	1/1

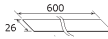
工事材料表		INSTALLATION MATERIALS		数量 Q'TY	用途/備考 REMARKS
番号 NO.	名称 NAME	略図 OUTLINE	型名/規格 DESCRIPTIONS	数量 Q'TY	用途/備考 REMARKS
1	圧着端子 CRIMP-ON LUG		FVS_5-S4(LF) K CODE NO. 000-166-760-11	3	
2	導電性テープ CONDUCTIVE TAPE		NO. 1181 1"X181X0.08mm CODE NO. 000-197-492-10	1	

(略図の寸法は、参考値です。 DIMENSIONS IN DRAWING FOR REFERENCE ONLY.)



FURUNO ELECTRIC CO., LTD.

C2392-M01-A

FURUNO

A-8

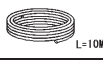
CODE NO.	000-036-244-00	10DA-X-9404 -1
TYPE	CP10-10100	1/1

工事材料表		INSTALLATION MATERIALS		数量 Q'TY	用途/備考 REMARKS
番号 NO.	名称 NAME	略図 OUTLINE	型名/規格 DESCRIPTIONS	数量 Q'TY	用途/備考 REMARKS
1	LANケーブル (CAT5E) CABLE ASSEMBLY		DT10SE35S0SLABVCV10T CODE NO. 000-195-119-11	1	
2	モジュラーコネクタ MODULAR CONNECTOR		MPSS8B-C CODE NO. 000-166-044-10	2	



(略図の寸法は、参考値です。 DIMENSIONS IN DRAWING FOR REFERENCE ONLY.)

FURUNO ELECTRIC CO., LTD.

C1363-M08-B

FURUNO

CODE NO.	000-036-245-00	10DA-X-9405 -1
TYPE	CP10-10110	1/1

工事材料表					
INSTALLATION MATERIALS					
番号 NO.	名称 NAME	略図 OUTLINE	型名/規格 DESCRIPTIONS	数量 Q'TY	用途/備考 REMARKS
1	LANケーブル (CAT5E) CABLE ASSEMBLY	 L=15M	DT10SE3S0SLABVQV15T CODE NO. 000-186-120-11	1	
2	モジュラーコネクタ MODULAR CONNECTOR		MPSS08-C CODE NO. 000-186-044-10	2	



(略図の寸法は、参考値です。 DIMENSIONS IN DRAWING FOR REFERENCE ONLY.)

FURUNO ELECTRIC CO., LTD.

C1363-M09-B

FURUNO

CODE NO.	000-036-246-00	10DA-X-9406 -0
TYPE	CP10-10120	1/1

工事材料表					
INSTALLATION MATERIALS					
番号 NO.	名称 NAME	略図 OUTLINE	型名/規格 DESCRIPTIONS	数量 Q'TY	用途/備考 REMARKS
1	LANケーブル (CAT5E) CABLE ASSEMBLY	 L=30M	DT10SE3S0SLABVQV30T CODE NO. 001-470-930-00	1	
2	モジュラーコネクタ MODULAR CONNECTOR		MPSS08-C CODE NO. 000-186-044-10	2	



(略図の寸法は、参考値です。 DIMENSIONS IN DRAWING FOR REFERENCE ONLY.)

FURUNO ELECTRIC CO., LTD.

C1363-M10-A

FURUNO

CODE NO.	000-036-247-00	10DA-X-9407 -0
TYPE	CP10-10130	1/1

工事材料表					
INSTALLATION MATERIALS					
番号 NO.	名称 NAME	略図 OUTLINE	型名/規格 DESCRIPTIONS	数量 Q'TY	用途/備考 REMARKS
1	LANケーブル (CAT5E) CABLE ASSEMBLY	 L=40M	DT10SE3S0SLABVQV40T CODE NO. 001-470-940-00	1	
2	モジュラーコネクタ MODULAR CONNECTOR		MPSS08-C CODE NO. 000-186-044-10	2	



(略図の寸法は、参考値です。 DIMENSIONS IN DRAWING FOR REFERENCE ONLY.)

FURUNO ELECTRIC CO., LTD.

C1363-M11-A

FURUNO

CODE NO.	000-036-248-00	10DA-X-9408 -0
TYPE	CP10-10140	1/1



工事材料表					
INSTALLATION MATERIALS					
番号 NO.	名称 NAME	略図 OUTLINE	型名/規格 DESCRIPTIONS	数量 Q'TY	用途/備考 REMARKS
1	LANケーブル (CAT5E) CABLE ASSEMBLY	 L=50M	DT10SE3S0SLABVQV50T CODE NO. 001-470-950-00	1	
2	モジュラーコネクタ MODULAR CONNECTOR		MPSS08-C CODE NO. 000-186-044-10	2	

(略図の寸法は、参考値です。 DIMENSIONS IN DRAWING FOR REFERENCE ONLY.)

FURUNO ELECTRIC CO., LTD.

C1363-M12-A



CODE NO.	000-036-722-00	100A-X-9424 -1
TYPE	CP10-10150	1/1

工事材料表					
INSTALLATION MATERIALS					
番号 NO.	名称 NAME	略図 OUTLINE	型名/規格 DESCRIPTIONS	数量 Q'TY	用途/備考 REMARKS
1	LANケーブル(CAT5E) CABLE ASSEMBLY		DT1C5E350SLABVGV100T CODE NO. 000-196-273-11	1	
2	モジュラーコネクタ MODULAR CONNECTOR		MPS588-C CODE NO. 000-166-044-10	2	

(略図の寸法は、参考値です。 DIMENSIONS IN DRAWING FOR REFERENCE ONLY.)

FURUNO ELECTRIC CO., LTD.



C1363-M23-B

NAME	OUTLINE	DESCRIPTION/CODE No.	Q'TY
工事材料 INSTALLATION MATERIALS			
LANケーブル(CAT5E) CABLE ASSEMBLY		DT1-C5E350 VCV L=10M 001-197-600-10	1
モジュラーコネクタ MODULAR CONNECTOR		MPS588-C 000-166-044-10	2

型式コード番号が2段の場合、下段より上段に代わる過渡期品であり、どちらが入っています。なお、品質は変わりません。
TWO TYPES AND CODES MAY BE LISTED FOR AN ITEM. THE LOWER PRODUCT MAY BE SHIPPED IN PLACE OF THE UPPER PRODUCT. QUALITY IS THE SAME.

(略図の寸法は、参考値です。 DIMENSIONS IN DRAWING FOR REFERENCE ONLY.)



C4473-Z23-A

NAME	OUTLINE	DESCRIPTION/CODE No.	Q'TY
工事材料 INSTALLATION MATERIALS			
LANケーブル(CAT5E) CABLE ASSEMBLY		DT1-C5E350 VCV L=20M 001-197-610-10	1
モジュラーコネクタ MODULAR CONNECTOR		MPS588-C 000-166-044-10	2

型式コード番号が2段の場合、下段より上段に代わる過渡期品であり、どちらが入っています。なお、品質は変わりません。
TWO TYPES AND CODES MAY BE LISTED FOR AN ITEM. THE LOWER PRODUCT MAY BE SHIPPED IN PLACE OF THE UPPER PRODUCT. QUALITY IS THE SAME.

(略図の寸法は、参考値です。 DIMENSIONS IN DRAWING FOR REFERENCE ONLY.)

C4473-Z24-A



NAME	OUTLINE	DESCRIPTION/CODE No.	Q'TY
工事材料 INSTALLATION MATERIALS			
LANケーブル(CAT5E) CABLE ASSEMBLY		DT1-C5E350 VCV L=30M 001-197-620-10	1
モジュラーコネクタ MODULAR CONNECTOR		MPS588-C 000-166-044-10	2

型式コード番号が2段の場合、下段より上段に代わる過渡期品であり、どちらが入っています。なお、品質は変わりません。
TWO TYPES AND CODES MAY BE LISTED FOR AN ITEM. THE LOWER PRODUCT MAY BE SHIPPED IN PLACE OF THE UPPER PRODUCT. QUALITY IS THE SAME.

(略図の寸法は、参考値です。 DIMENSIONS IN DRAWING FOR REFERENCE ONLY.)

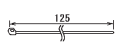

C4473-Z25-A

CODE NO.	001-418-400-00	24AL-X-9409 -0
TYPE	CP24-02301	1/1

工事材料表 INSTALLATION MATERIALS					
番号 NO.	名称 NAME	略図 OUTLINE	型名/規格 DESCRIPTIONS	数量 Q'TY	用途/備考 REMARKS
1	自己付着ネジ SELF-TAPPING SCREW		5X20 SUS304 CODE NO. 000-162-688-10	2	
2	ケーブルタイ CABLE TIE		CV-125M CODE NO. 000-172-164-10	2	
3	ワッシャー WASHER HEAD SCREW #8		M3X12 SUS304 CODE NO. 000-162-648-10	4	



型式/コード番号が2般の場合、下段より上段に代わる通読商品であり、どちらが入っています。なお、品質は変わりません。
TWO TYPES AND CODES MAY BE LISTED FOR AN ITEM. THE LOWER PRODUCT MAY BE SHIPPED IN PLACE OF THE UPPER PRODUCT. QUALITY IS THE SAME.
(略図の寸法は、参考値です。 DIMENSIONS IN DRAWING FOR REFERENCE ONLY.)

CODE NO.	001-418-410-00	24AL-X-9512 -0
TYPE	FP24-00801	1/1

付属品表 ACCESSORIES					
番号 NO.	名称 NAME	略図 OUTLINE	型名/規格 DESCRIPTIONS	数量 Q'TY	用途/備考 REMARKS
1	卓上取付板 DESKTOP FIXING PLATE		14-078-2911-0 CODE NO. 100-364-788-10	1	
2	USBシート USB SHEET		24-014-1411-0 CODE NO. 100-372-088-10	1	
3	ワッシャー WASHER HEAD SCREW #8		M3X8 SUS304 CODE NO. 000-162-648-10	2	



型式/コード番号が2般の場合、下段より上段に代わる通読商品であり、どちらが入っています。なお、品質は変わりません。
TWO TYPES AND CODES MAY BE LISTED FOR AN ITEM. THE LOWER PRODUCT MAY BE SHIPPED IN PLACE OF THE UPPER PRODUCT. QUALITY IS THE SAME.
(略図の寸法は、参考値です。 DIMENSIONS IN DRAWING FOR REFERENCE ONLY.)

CODE NO.	001-581-570-00	026U-X-9401 -0
TYPE	CP02-09801	1/1

工事材料表 INSTALLATION MATERIALS					
番号 NO.	名称 NAME	略図 OUTLINE	型名/規格 DESCRIPTIONS	数量 Q'TY	用途/備考 REMARKS
1	圧着端子 CRIMP-ON LUG		FVS 5-84(LF) K CODE NO. 000-166-760-11	3	
2	導電性テープ CONDUCTIVE TAPE		NO.1181 1"X18"X0.09mm CODE NO. 000-197-492-10	1	

(略図の寸法は、参考値です。 DIMENSIONS IN DRAWING FOR REFERENCE ONLY.)

CODE NO.	001-569-280-00	026U-X-9301 -0 1/1
TYPE	SP02-06001	BOX NO. P

SHIP NO.	SPARE PARTS LIST FOR		U S E			SETS PER VESSEL
ITEM NO.	NAME OF PART	OUTLINE	DRG. NO. OR TYPE NO.	QUANTITY		REMARKS/CODE NO.
				WORKING	SPARE	
				PER SET	PER VES	
1	ガラス管ヒューズ GLASS TUBE FUSE		FBD0-4 125V 15A PBF	1	1	2 000-158-827-10
2	ガラス管ヒューズ GLASS TUBE FUSE		FBD0-4 125V 7A PBF	0	0	2 000-164-985-10
MFR'S NAME			FURUNO ELECTRIC CO., LTD.	DRG. NO.		C2392-P01-B 1/1

(略図の寸法は、参考値です。 DIMENSIONS IN DRAWING FOR REFERENCE ONLY.)

FURUNO

CODE NO.	001-249-760-00	03HL-X-9303-2 1/1
TYPE	SP03-17661	BOX NO. P

SHIP NO.	SPARE PARTS LIST FOR	U S E	SETS PER VESSEL	ITEM NO.	NAME OF PART	OUTLINE	DRG. NO. OR TYPE NO.	QUANTITY			REMARKS/CODE NO.
								WORKING PER SET	PER VES	SPARE	
				1	E1-X GLASS TUBE FUSE	<p>30 Φ 6</p>	FG80-A 250V SA PBF	1	1	2	000-155-840-10
MFR'S NAME	FURUNO ELECTRIC CO., LTD.			DRG. NO.	C3619-P01-C		1/1				

(略圖の寸法は、参考値です。 DIMENSIONS IN DRAWING FOR REFERENCE ONLY.)

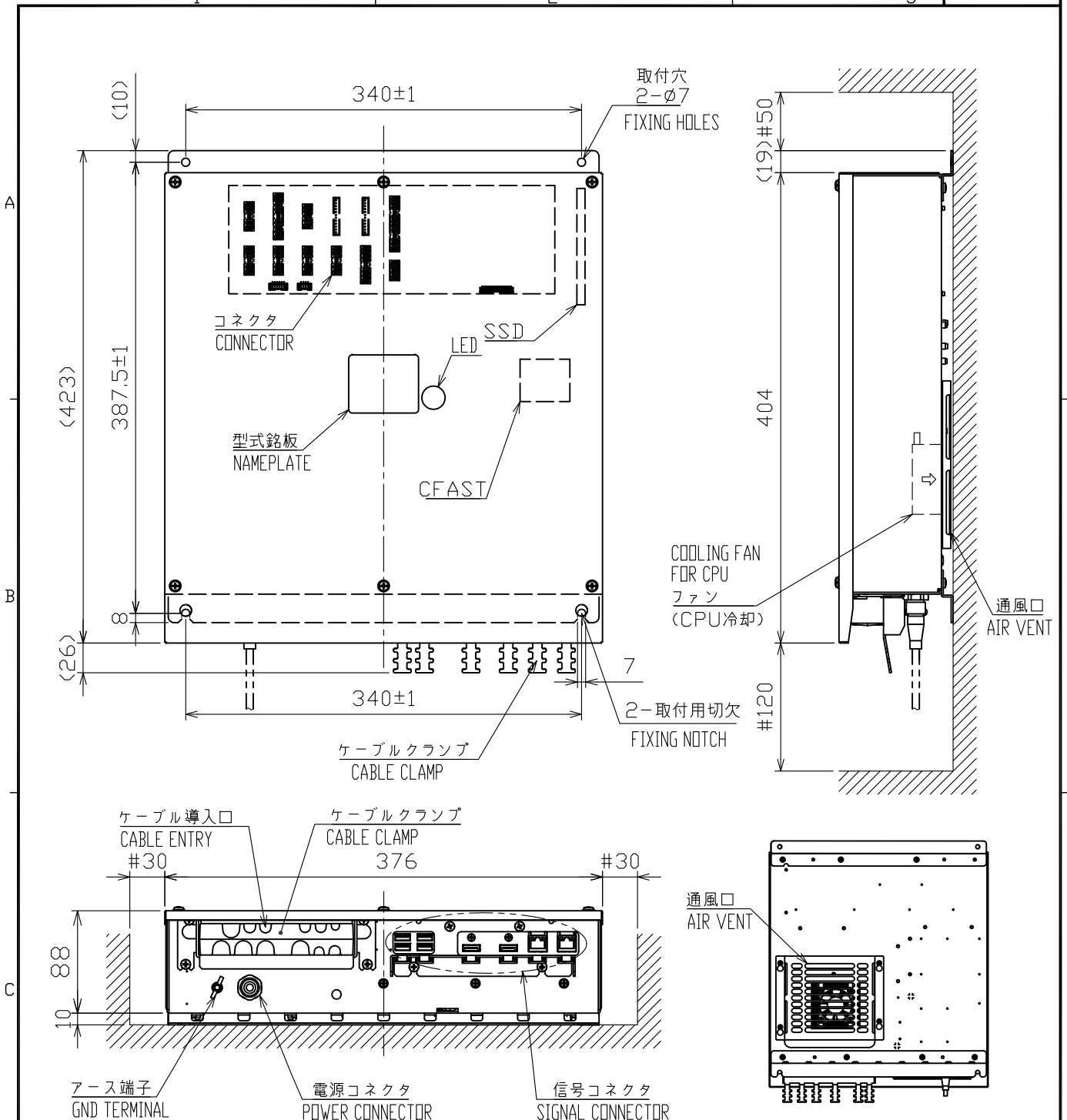

注記

- 1) 指定外の寸法公差は表 1 による。
- 2) #印寸法は最小サービス空間寸法とする。
- 3) 取付用ネジは M6 ボルト、またはコーチネジ呼び径 6 を使用のこと。

NOTE

1. TABLE 1 INDICATES TOLERANCE OF DIMENSIONS WHICH IS NOT SPECIFIED.
2. #: MINIMUM SERVICE CLEARANCE.
3. USE M6 BOLTS OR COACH SCREWS $\phi 6$ FOR FIXING THE UNIT.

表 1 TABLE 1

寸法区分 (mm) DIMENSION	公差 (mm) TOLERANCE
$L \leq 50$	± 1.5
$50 < L \leq 100$	± 2.5
$100 < L \leq 500$	± 3

DRAWN	5/Sep/2019 T.YAMASAKI	TITLE	CV-380
CHECKED	5/Sep/2019 H.MAKI	名称	制御部 (壁掛・卓上装備)
APPROVED	9/Sep/2019 H.MAKI	FCV-38	外寸図
SCALE	1/5	MASS	7.6 $\pm 10\%$ kg
DWG. No.	C2392-G01-A	REF. No.	02-177-601G-0
		NAME	PROCESSOR UNIT (BULKHEAD/TABLETOP MOUNT)
			OUTLINE DRAWING

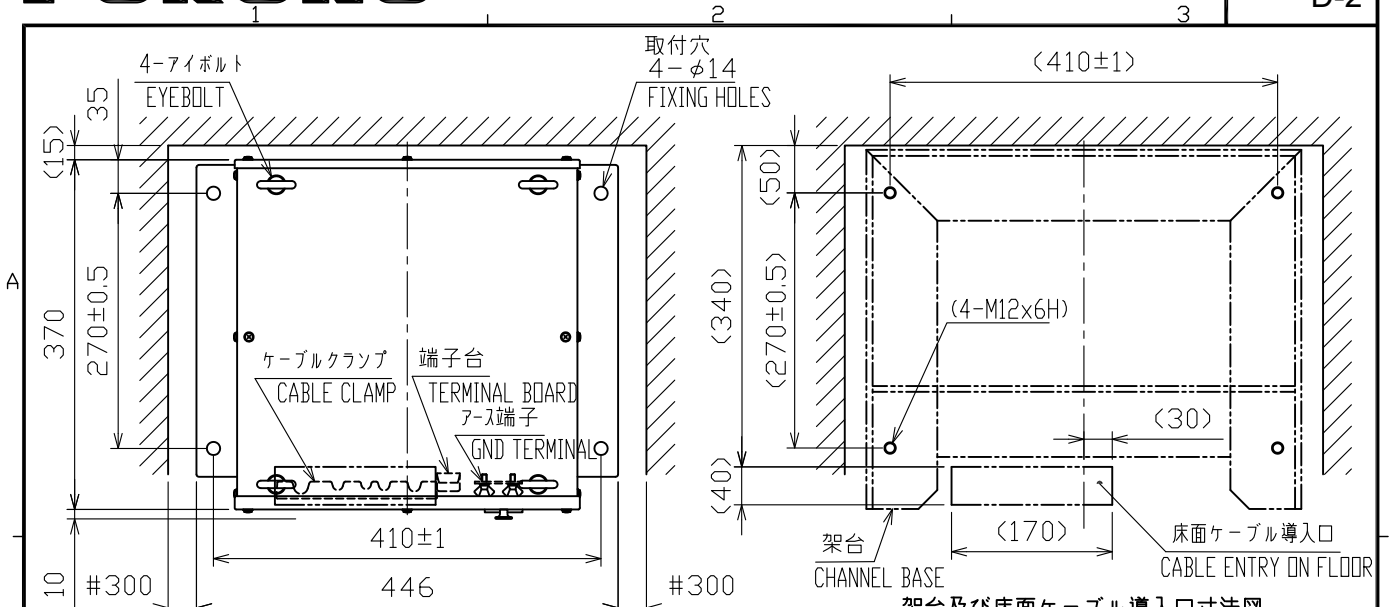

架台及び床面ケーブル導入口寸法図
CHANNEL BASE & FLOOR CABLE ENTRY

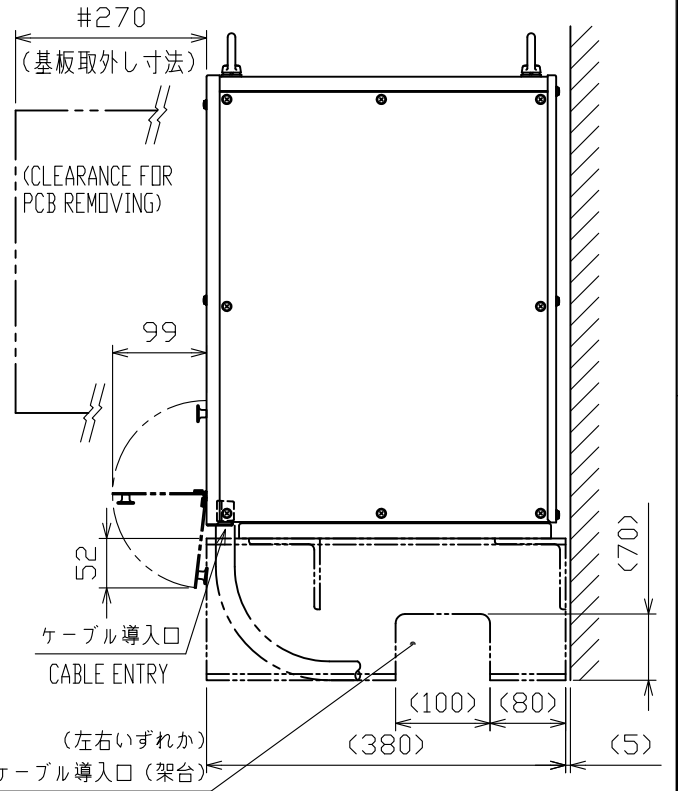
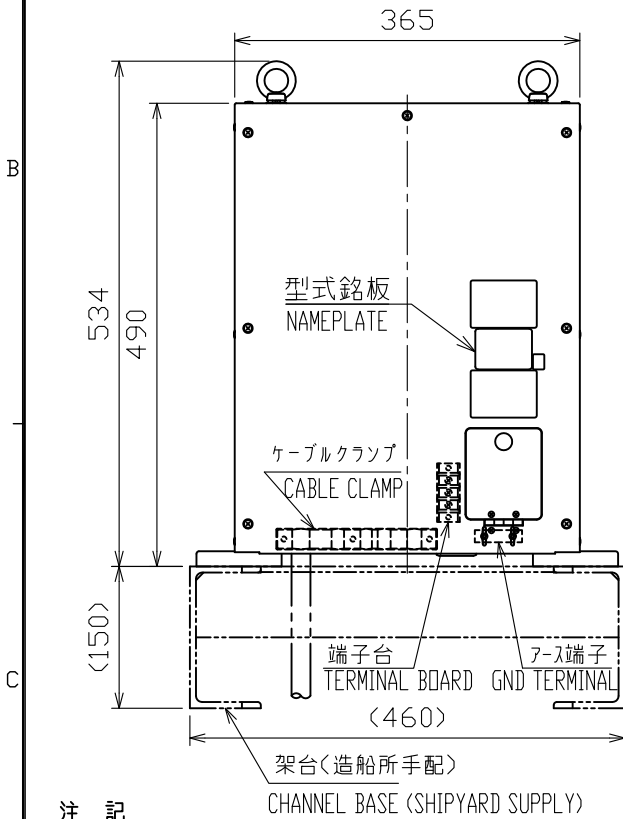

注記

- 1) 指定外の寸法公差は表1による。
- 2) #印寸法は最小サービス空間寸法とする。
- 3) 取付用ネジはM12ボルト(材質:SUS304)を使用のこと。
- 4) 架台及び床面ケーブル導入口の寸法は参考寸法とする。
直接床置きの場合のみ床面ケーブル導入口を設け、架台取付けの場合架台(材質:SS400)は造船所手配とする。

NOTE

1. TABLE 1 INDICATES TOLERANCE OF DIMENSIONS WHICH IS NOT SPECIFIED.
2. #: MINIMUM SERVICE CLEARANCE.
3. USE M12 BOLTS (SUS 304) FOR FIXING THE UNIT.
4. DIMENSIONS OF CHANNEL BASE AND CABLE ENTRY ON FLOOR SHOW FOR REFERENCE. THE CABLE ENTRY ON FLOOR IS REQUIRED FOR FLOOR MOUNT DIRECTLY. CHANNEL BASE (SS400) SHOULD BE SUPPLIED LOCALLY.

表1 TABLE 1

寸法区分 (mm) DIMENSION	公差 (mm) TOLERANCE
$L \leq 50$	± 1.5
$50 < L \leq 100$	± 2.5
$100 < L \leq 500$	± 3
$500 < L \leq 1000$	± 4

DRAWN 3/Aug/2020 T.YAMASAKI	TITLE CV-382
CHECKED 3/Aug/2020 H.MAKI	名称 送受信装置 (床置装備)
APPROVED 3/Aug/2020 H.MAKI	FCV-38 外寸図
SCALE 1/8 MASS 33 ±10% kg	NAME TRANSCEIVER UNIT (FLOOR MOUNT)
DWG. No. C2392-G02-B	REF. No. 02-177-500G-1 OUTLINE DRAWING

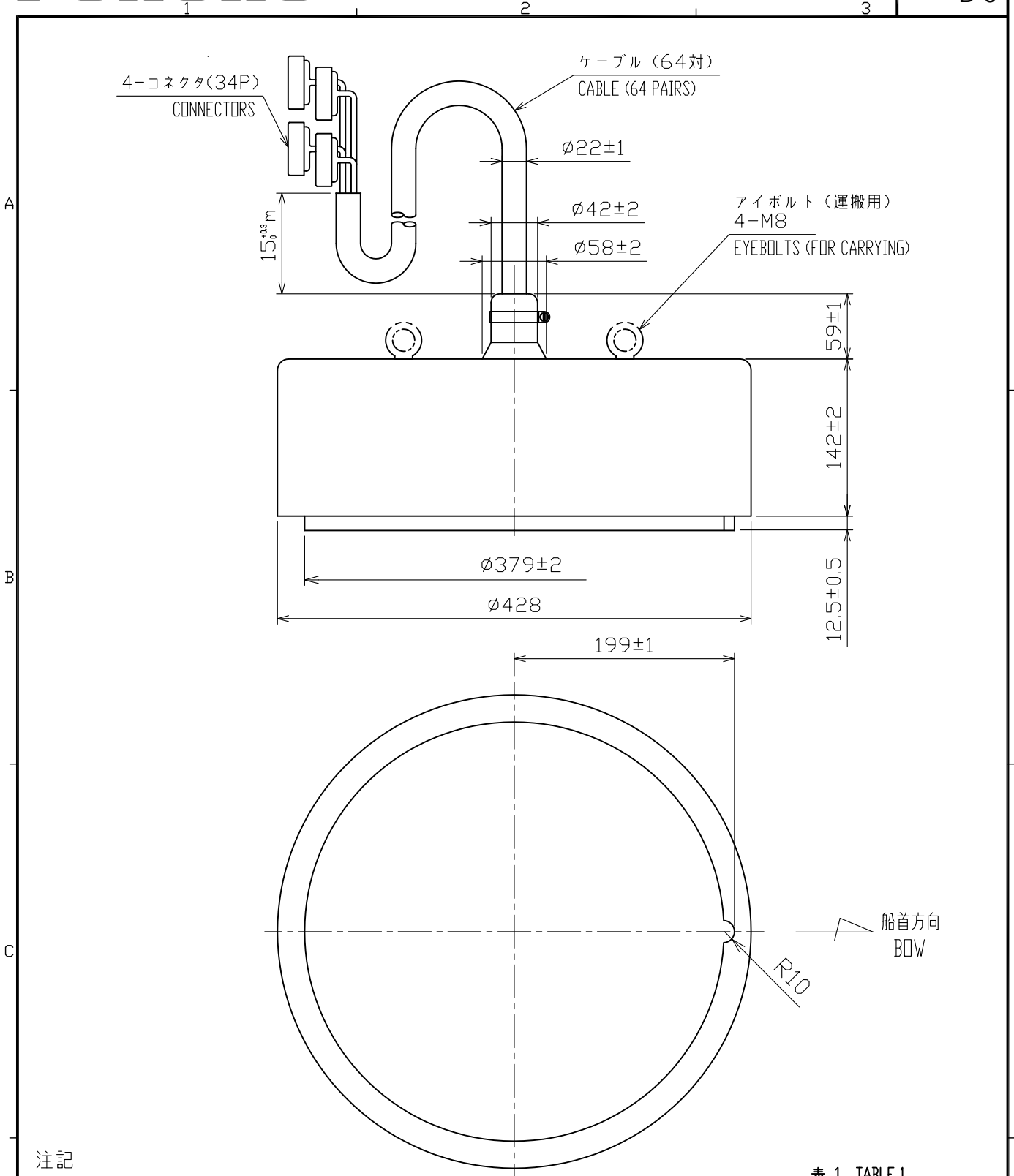

注記

- 1) 指定外の寸法公差は表1による。
- 2) 旧品はケーブル径が小さくなっています(ø19.4)。
貫通金物を使用するとき、ケーブル径に合うパッキンを使用してください。

NOTE

- 1. TABLE 1 INDICATES TOLERANCE OF DIMENSIONS WHICH IS NOT SPECIFIED.
- 2. PREVIOUS SHIPPING HAS A SMALLER DIAMETER CABLE (ø19.4).
USE A SUITABLE SIZE GASKET TO PATH THE THRU-HULL PIPE.

表 1 TABLE 1

寸法区分 (mm) DIMENSION	公差 (mm) TOLERANCE
L ≤ 50	±1.5
50 < L ≤ 100	±2.5
100 < L ≤ 500	±3

DRAWN	3/Oct/2019 I.YAMASAKI		TITLE	CV-303	
CHECKED	3/Oct/2019 H.MAKI		名称	送受波器	
APPROVED	3/Oct/2019 H.MAKI	FCV-30/38		外寸図	
SCALE	1/5	MASS 40 ±10% Kg	質量はケーブルを含む。 MASS INCLUDES CABLE.	NAME	TRANSDUCER
DWG. No.	C2373-G01-C	REF. No.	02-153-400G-3		OUTLINE DRAWING

表 1 TABLE 1

寸法区分 (mm) DIMENSION	公差 (mm) TOLERANCE
$L \leq 50$	± 1.5
$50 < L \leq 100$	± 2.5
$100 < L \leq 500$	± 3

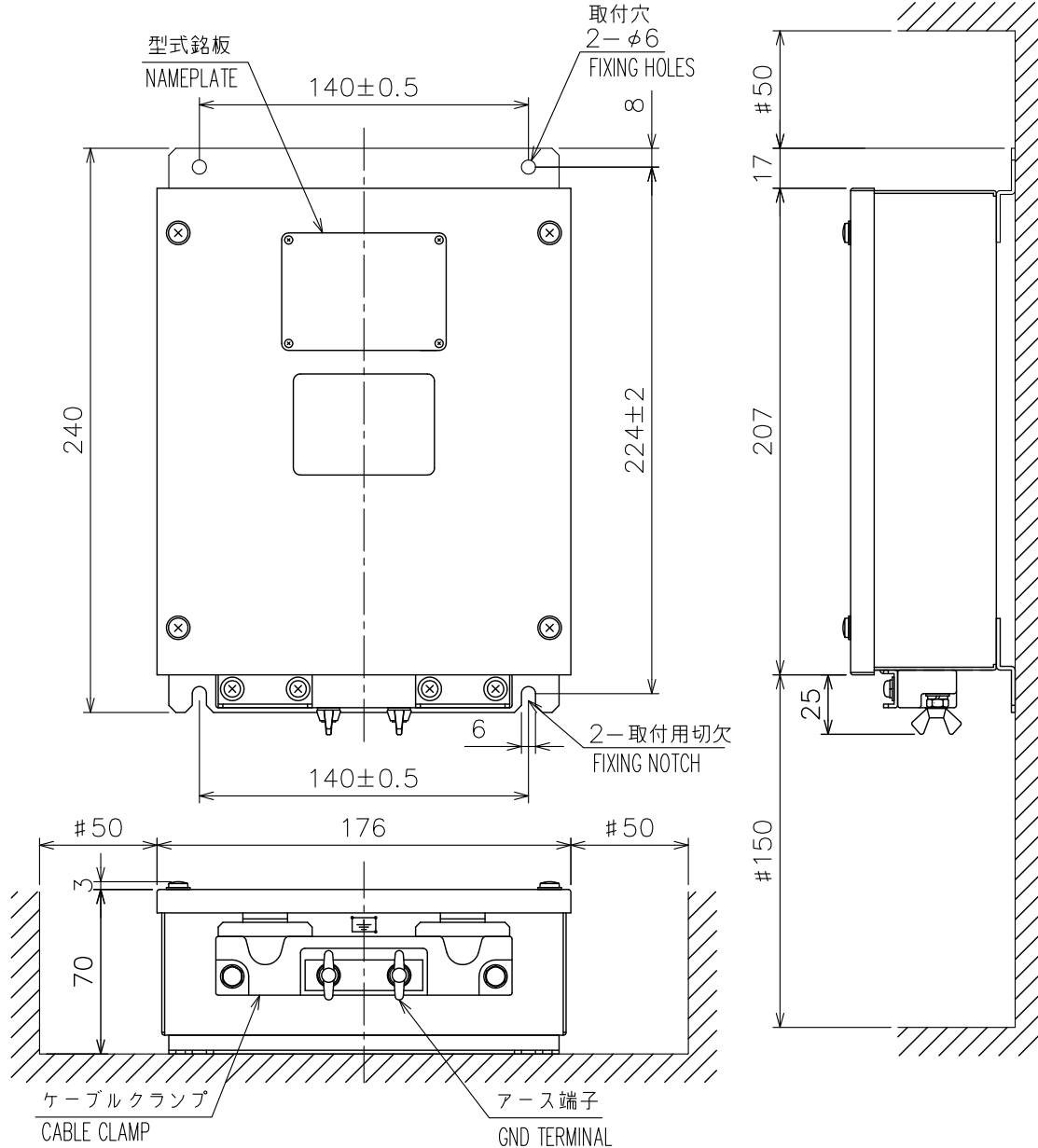

注 記

- 1) 指定外の寸法公差は表 1 による。
- 2) # 印寸法は最小サービス空間寸法とする。
- 3) 取付用ネジは M5 ボルトを使用のこと。

NOTE

1. TABLE 1 INDICATES TOLERANCE OF DIMENSIONS WHICH IS NOT SPECIFIED.
2. #: MINIMUM SERVICE CLEARANCE.
3. USE M5 BOLTS FOR FIXING THE UNIT.

DRAWN 6/Sep/2019 T.YAMASAKI	TITLE CV-304
CHECKED 6/Sep/2019 H.MAKI	名称 接続箱 (壁掛装備)
APPROVED 26/Sep/2019 H.MAKI	FCV-30/38 外寸図
SCALE 1/3 MASS 1.6 ±10% kg	NAME JUNCTION BOX (BULKHEAD MOUNT)
DWG. No. C2373-G05-B	REF. No. 02-153-500G-0 OUTLINE DRAWING



表1 TABLE 1

寸法区分 (mm) DIMENSION	公差 (mm) TOLERANCE
L ≤ 50	± 1.5
50 < L ≤ 100	± 2.5
100 < L ≤ 500	± 3

- 注記 1) 指定外の寸法公差は表1による。
 2) #印寸法は最小サービス空間寸法とする。
 3) 取付ネジはセムスネジ B M3 × 1.2 を使用のこと。壁の厚さ (A) は最小2、最大4とする。それ以外はねじ長さを A + 8 ± 2 とする。
- NOTE 1. TABLE 1 INDICATES TOLERANCE OF DIMENSIONS WHICH IS NOT SPECIFIED.
 2. # MINIMUM SERVICE CLEARANCE.
 3. USE SEMS B SCREWS M3x1.2 FOR BULKHEAD THICKNESS (A); 2 ≤ A ≤ 4. OR SCREW LENGTH: A+8±2.

DRAWN	14/Jun/2018	T.YAMASAKI	TITLE	RCU-026
CHECKED	14/Jun/2018	H.MAKI	名称	トラックボール操作部 (卓上装備)
APPROVED	14/Jun/2018	H.MAKI	外寸図	
SCALE	1/2	質量 1.4 kg FMD-3200 質量は5mケーブルを含む。 MASS INCLUDES 5m CABLE.	NAME	TRACKBALL CONTROL UNIT (TABLETOP MOUNT)
DWG.No.	C4473-G05-C	REF.No.	24-014-150G-2	OUTLINE DRAWING

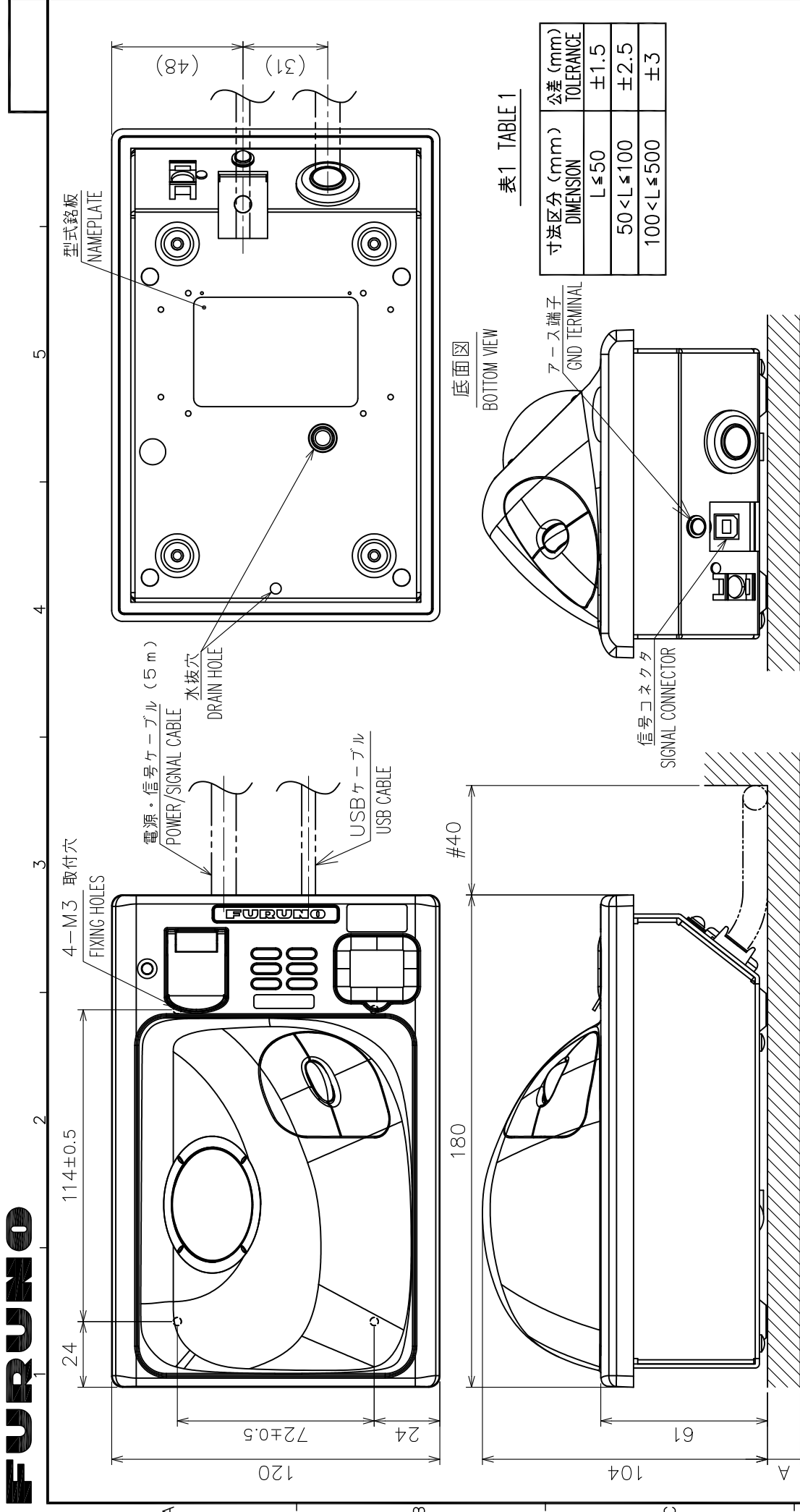
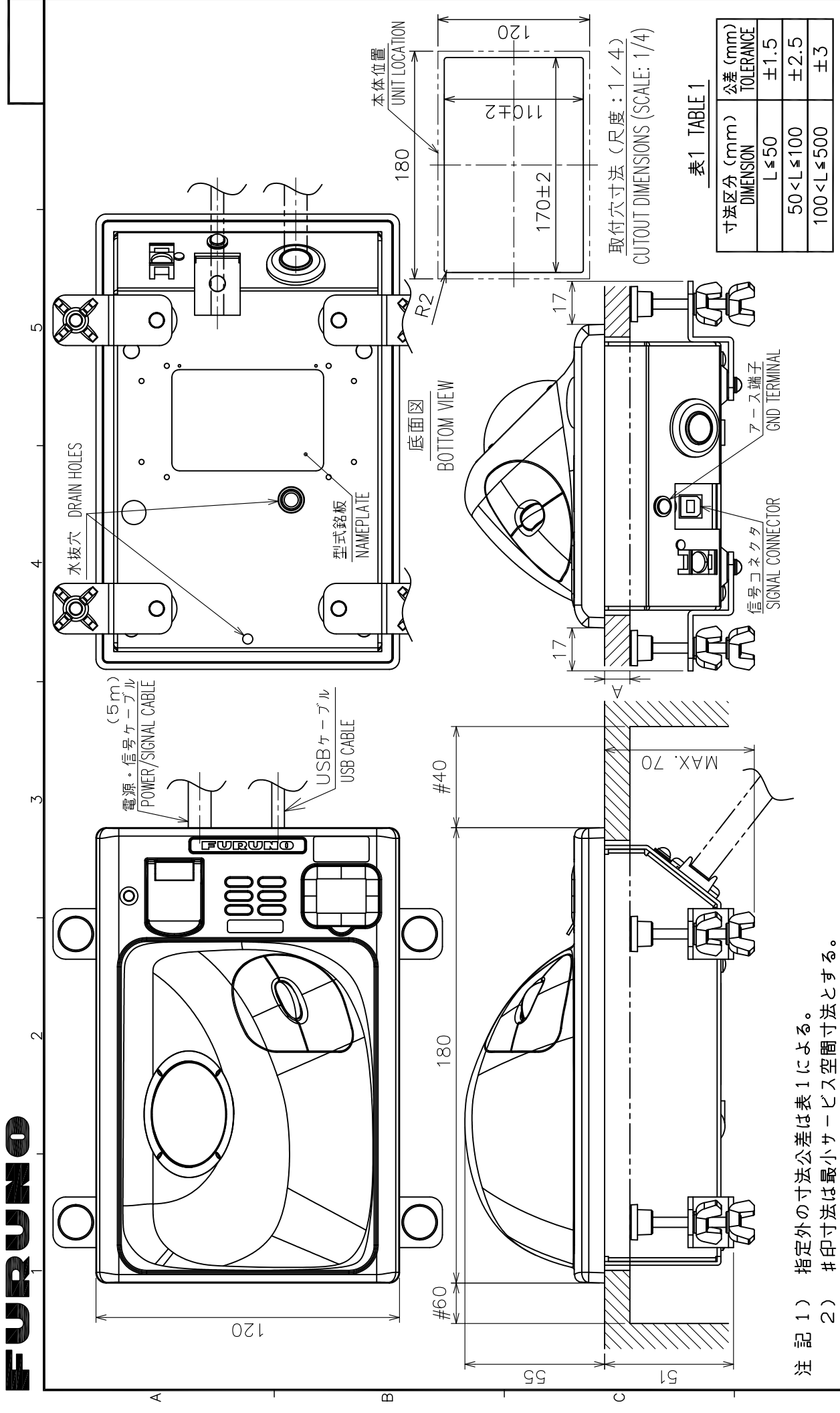

DRAWN	14/Jun/2018	T. YAMASAKI	TITLE	RCU-026
CHECKED	14/Jun/2018	H. MAKI	名称	トラックボール操作部 (埋込装備)
APPROVED	14/Jun/2018	H. MAKI	外寸図	
SCALE	1/2	質量 1.5 kg 質量は5mケーブルを含む。 ±10% MASS INCLUDES 5m CABLE.	NAME	TRACKBALL CONTROL UNIT (FLUSH MOUNT)
DWG.No.	C4473-G06-C	REF.No.	24-014-160G-2	OUTLINE DRAWING

- 注記 1) 指定外の寸法公差は表1による。
 2) #印寸法は最小サービスマン寸法とする。
 3) 壁の厚さ(A)は最小10mm、最大20mmとする。
- NOTE 1. TABLE 1 INDICATES TOLERANCE OF DIMENSIONS WHICH IS NOT SPECIFIED.
 2. #: MINIMUM SERVICE CLEARANCE.
 3. BULKHEAD THICKNESS (A): 10 ≤ A ≤ 20.

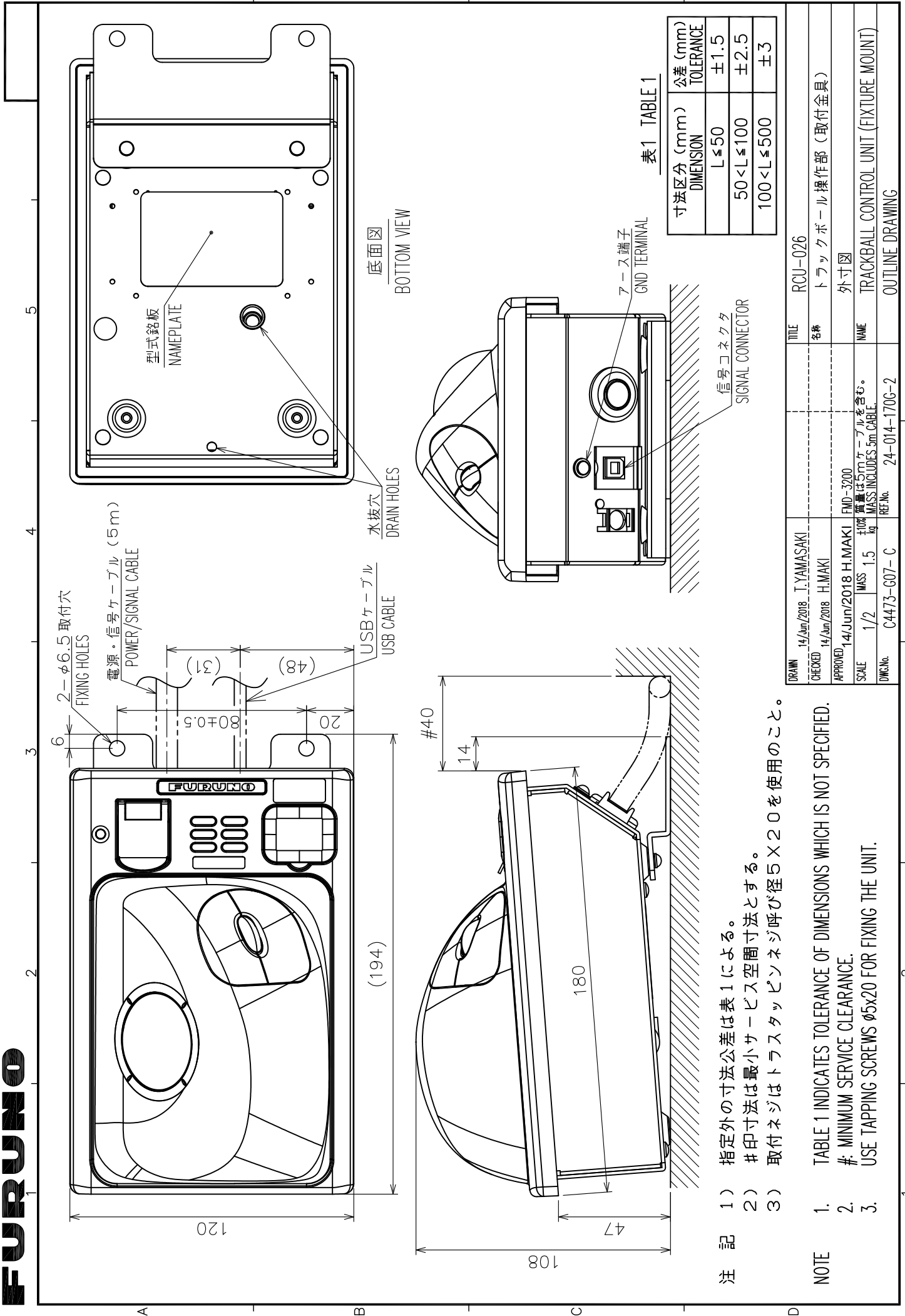

- 注記**
- 1) 指定外の寸法公差は表1による。
 - 2) #印寸法は最小サービスマージン寸法とする。
 - 3) 取付ネジはトラスタップピンネジ呼び径5×20を使用のこと。
- NOTE**
1. TABLE 1 INDICATES TOLERANCE OF DIMENSIONS WHICH IS NOT SPECIFIED.
 2. #: MINIMUM SERVICE CLEARANCE.
 3. USE TAPPING SCREWS φ5x20 FOR FIXING THE UNIT.



表1 TABLE 1

寸法区分 (mm) DIMENSIONS	公差 (mm) TOLERANCE
0 < L ≤ 50	±1.5
50 < L ≤ 100	±2.5
100 < L ≤ 500	±3

注記

1) 指定なき寸法公差は表1による。

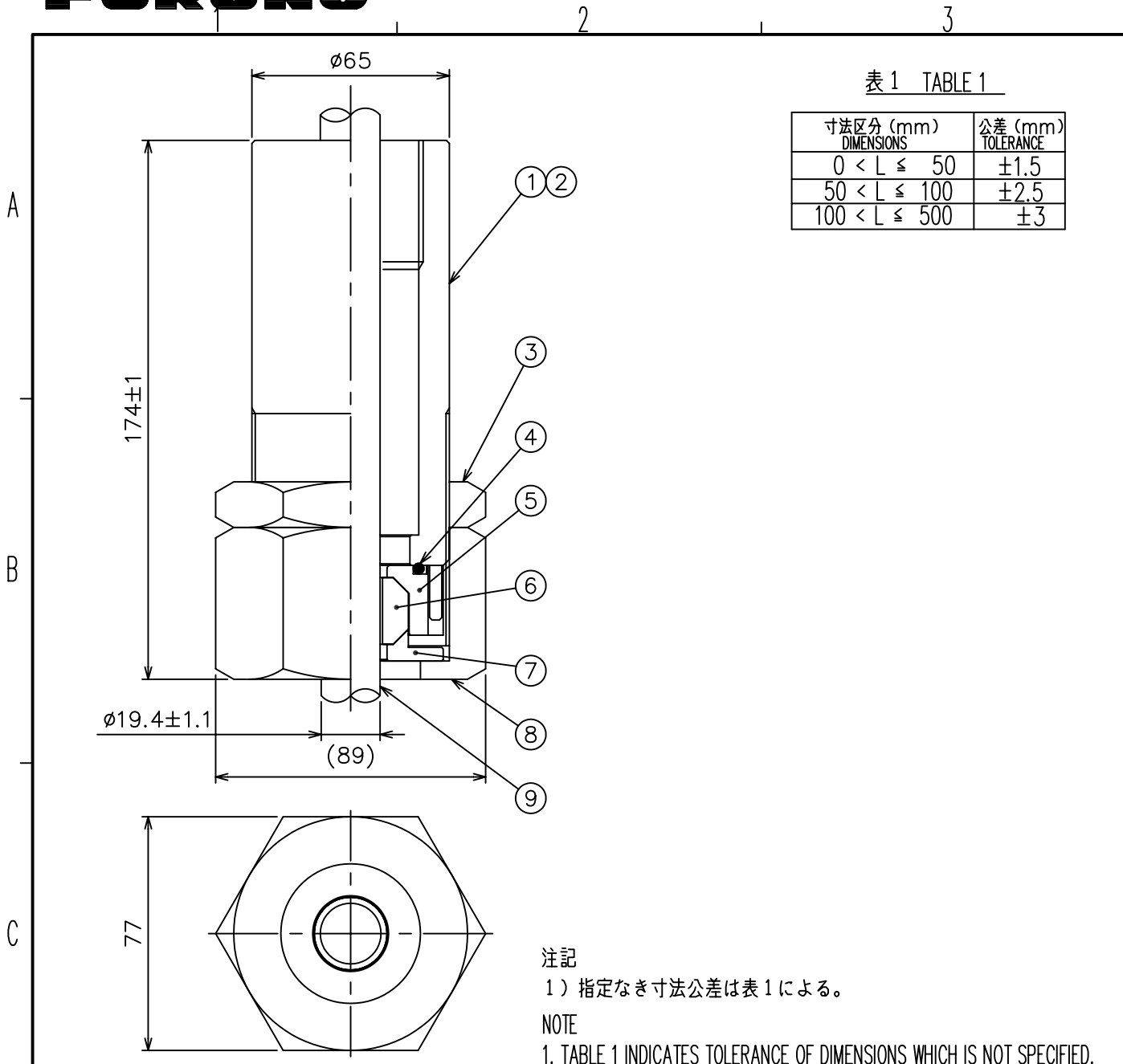
NOTE

1. TABLE 1 INDICATES TOLERANCE OF DIMENSIONS WHICH IS NOT SPECIFIED.

9	ケーブル CABLE		1		
8	キャップナット CAP NUT	SS400	1	TFB-7002	
7	締付ワッシャ GLAND WASHER	SUS316	1	02-153-4202	
6	グラウンドパッキン PACKING RUBBER	CR	1	02-153-4203	
5	回り止めワッシャ WASHER	SUS316	1	02-153-4201	
4	Oリング O-RING	NBR	1	WG-1	
3	貫通金物用止めナット FIXING NUT	SS400	1	TWB-3005	
2	座金止めピン FIXING PIN	SS400	2	TWB-3011	
1	電線貫通金物用体 THRU-HULL PIPE	SS400	1	TFB-7001	

DRAWN	Jun. 9 '05 T.YAMASAKI	TITLE	TFB-1600
CHECKED	Jun. 9 '05 T.TAKENO	名称	電線貫通金物
APPROVED	Jun. 10 '05 <i>T. Matsuyuchi</i>	FCV-30	外寸図
SCALE	1/2 MASS 3 ±10% kg	NAME	THRU-HULL PIPE
DWG.No.	C2373-G07-A	REF.No.	02-153-4200-1
		OUTLINE DRAWING	

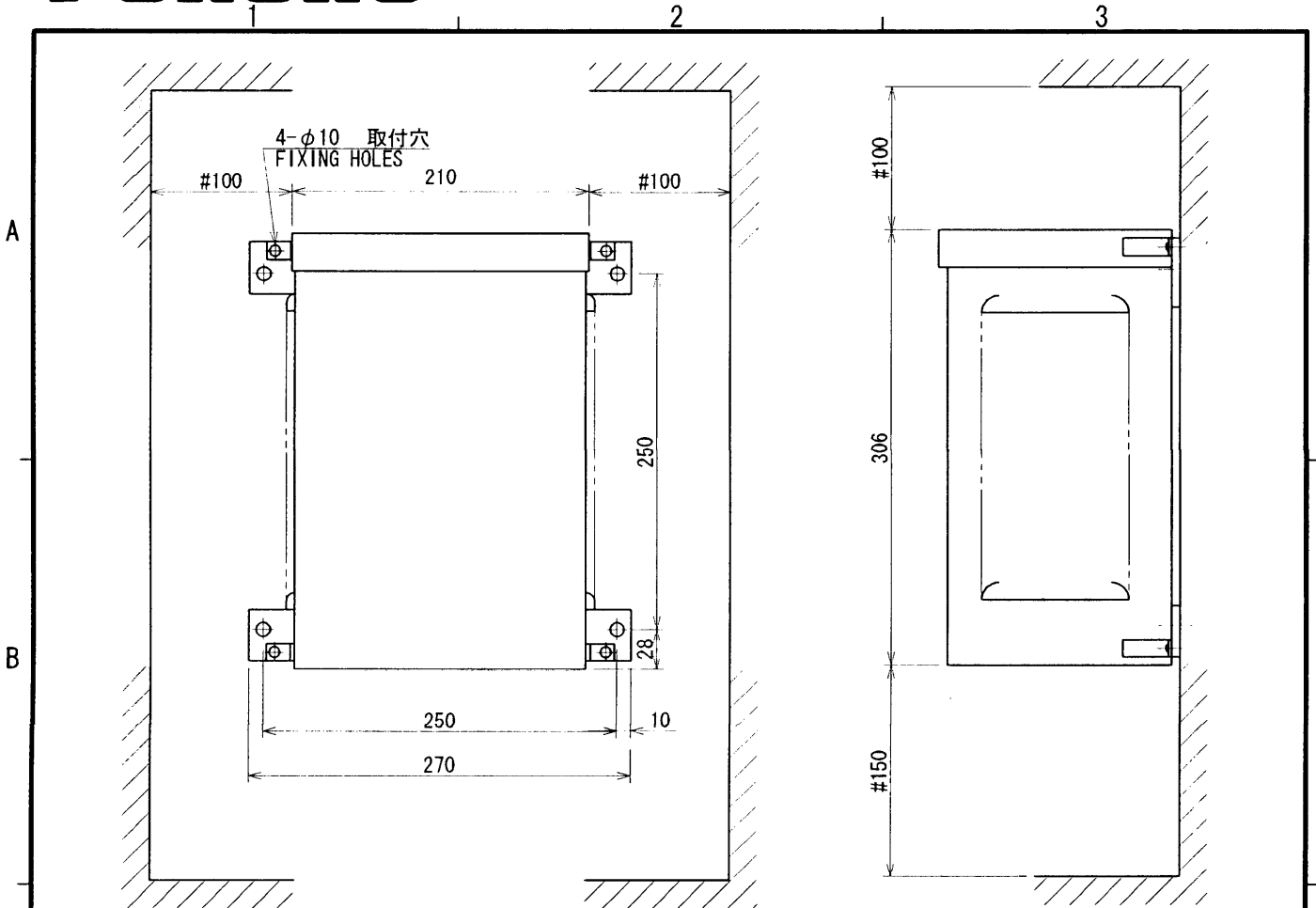

NOTE 1. # : 推奨サービス空間
RECOMMENDED SERVICE CLEARANCE.

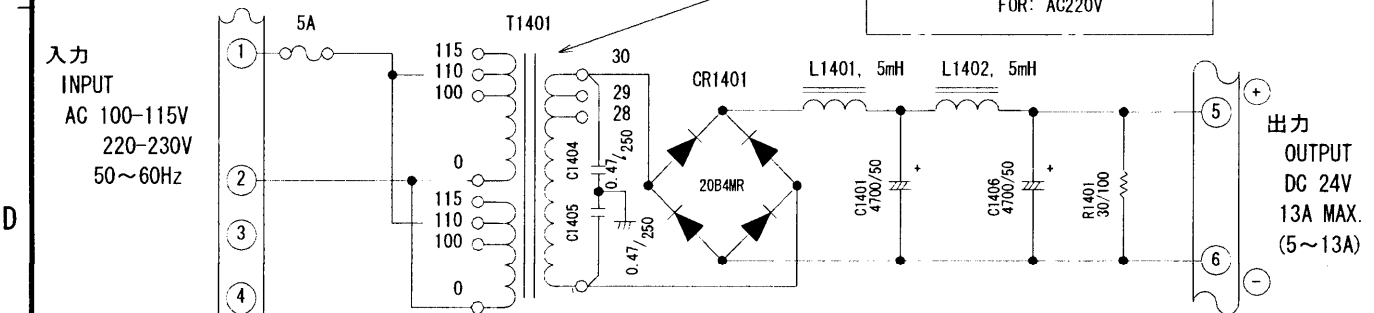
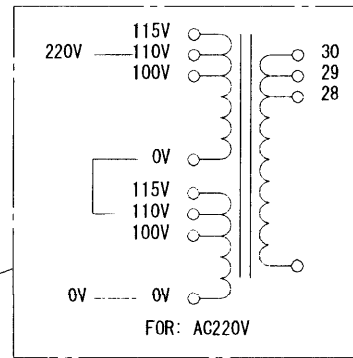
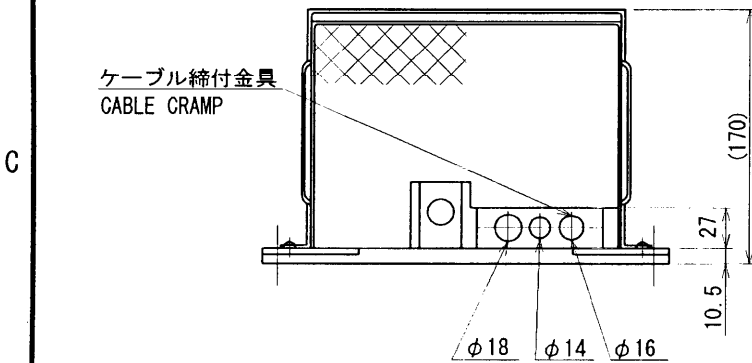

注記 AC220V入力に対しては T1401の一次巻線を直列に接続する。
NOTE FOR 220V AC INPUT, CONNECT T1401 PRIMARY WINDINGS IN SERIES.

DRAWN	Aug 16 '00 T.YAMASAKI
CHECKED	Aug 17 '00 Y.Kim
APPROVED	Aug 17 '00 Y.Kim
SCALE	1/5
MASS	±10% 17 kg
DWG. No.	C3002-002- N

TITLE	RU-1746B-2
名称	整流器
	外寸図
NAME	RECTIFIER UNIT
	OUTLINE DRAWING

表1 TABLE 1

寸法区分 (mm) DIMENSION	公差 (mm) TOLERANCE
$L \leq 50$	± 1.5
$50 < L \leq 100$	± 2.5
$100 < L \leq 500$	± 3

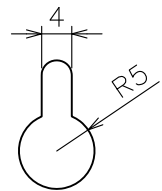
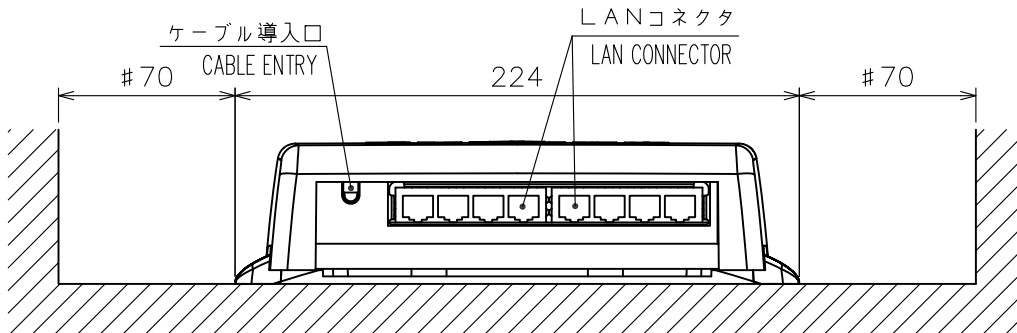
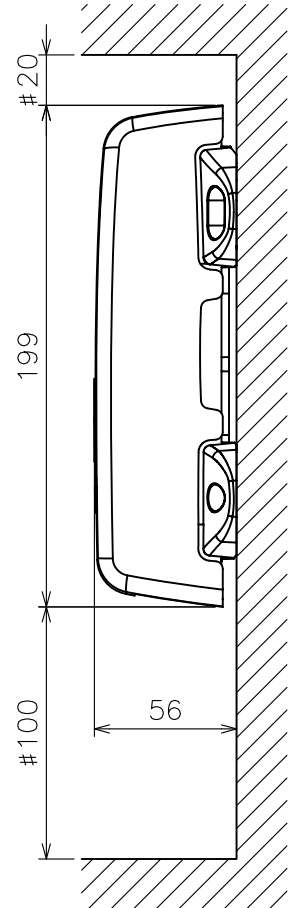
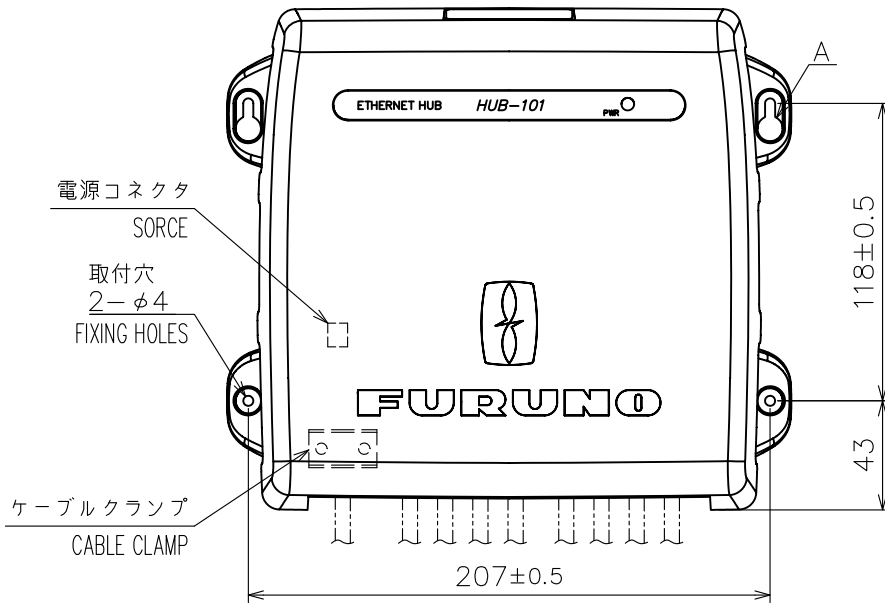
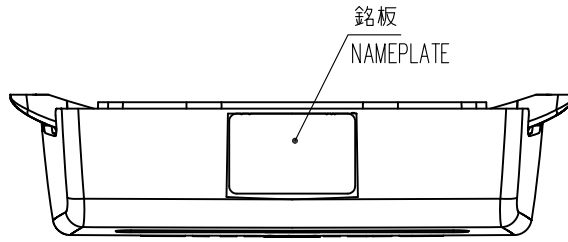

- 注記 1) #印寸法は最小サービス空間寸法とする。
 2) 指定外の寸法公差は表1による。
 3) 取付用ネジはトラスタッピンネジ呼び径3×20を使用のこと。
- NOTE 1. # MINIMUM SERVICE CLEARANCE.
 2. TABLE 1 INDICATES TOLERANCE OF DIMENSIONS WHICH IS NOT SPECIFIED.
 3. USE TAPPING SCREWS $\phi 3 \times 20$ FOR FIXING THE UNIT.

A部詳細 (尺度: 1/1)
 DETAIL OF A (SCALE: 1/1)

DRAWN	Oct. 18 '07 T.YAMASAKI	TITLE	HUB-101
CHECKED	Oct. 18 '07 T.TAKENO	名称	イーサネットハブ
APPROVED	Oct. 22 '07 R.Esumi		外寸図
SCALE	1/3 MASS 1.1 ±10% kg	NAME	ETHERNET HUB
DWG.No.	C4444-G03-A	REF.No.	19-028-420G-1
			OUTLINE DRAWING

表1 TABLE 1

寸法区分(mm) DIMENSION	公差(mm) TOLERANCE
0 < L ≤ 50	±1.5
50 < L ≤ 100	±2.5
100 < L ≤ 500	±3

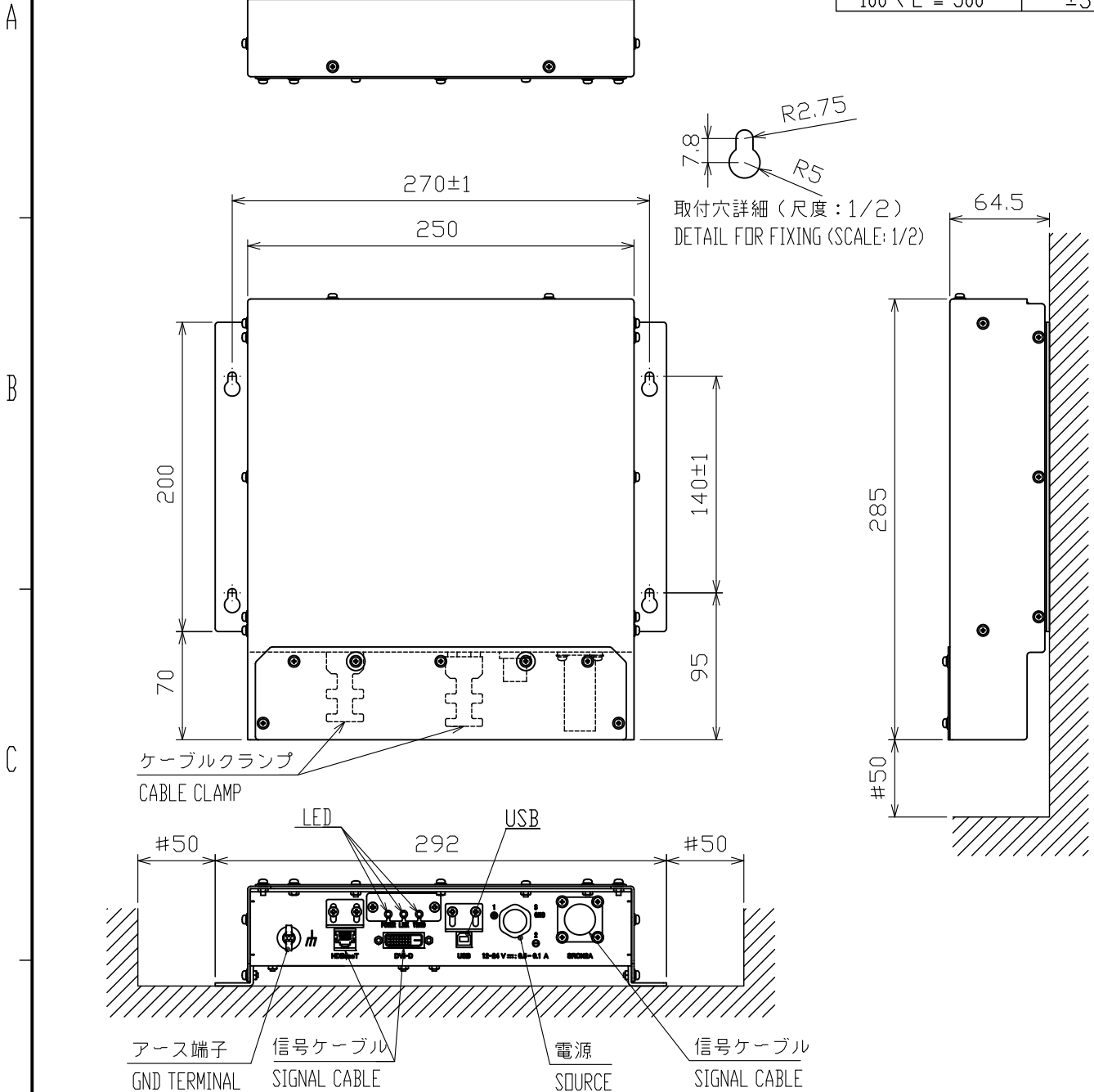

注記
1) 指定なき寸法公差は表1による。

NOTE
1. TABLE 1 INDICATES TOLERANCE OF DIMENSIONS WHICH IS NOT SPECIFIED.

DRAWN 9/Oct/2019 T.YAMASAKI		TITLE TM000-FDX06 TX
CHECKED 9/Oct/2019 H.MAKI		名称 送信機 (壁掛・卓上装備)
APPROVED 9/Oct/2019 H.MAKI	FCV-T900 FAR-15x3	外寸図
SCALE 1/4	MASS 1.4 ±10% kg	NAME TRANSMITTER UNIT (BULKHEAD/TABLETOP MOUNT)
DWG. No. C3638-G03-A	REF. No. PTM000-FDX06A-13	OUTLINE DRAWING

表1 TABLE 1

寸法区分(mm) DIMENSION	公差(mm) TOLERANCE
$0 < L \leq 50$	± 1.5
$50 < L \leq 100$	± 2.5
$100 < L \leq 500$	± 3

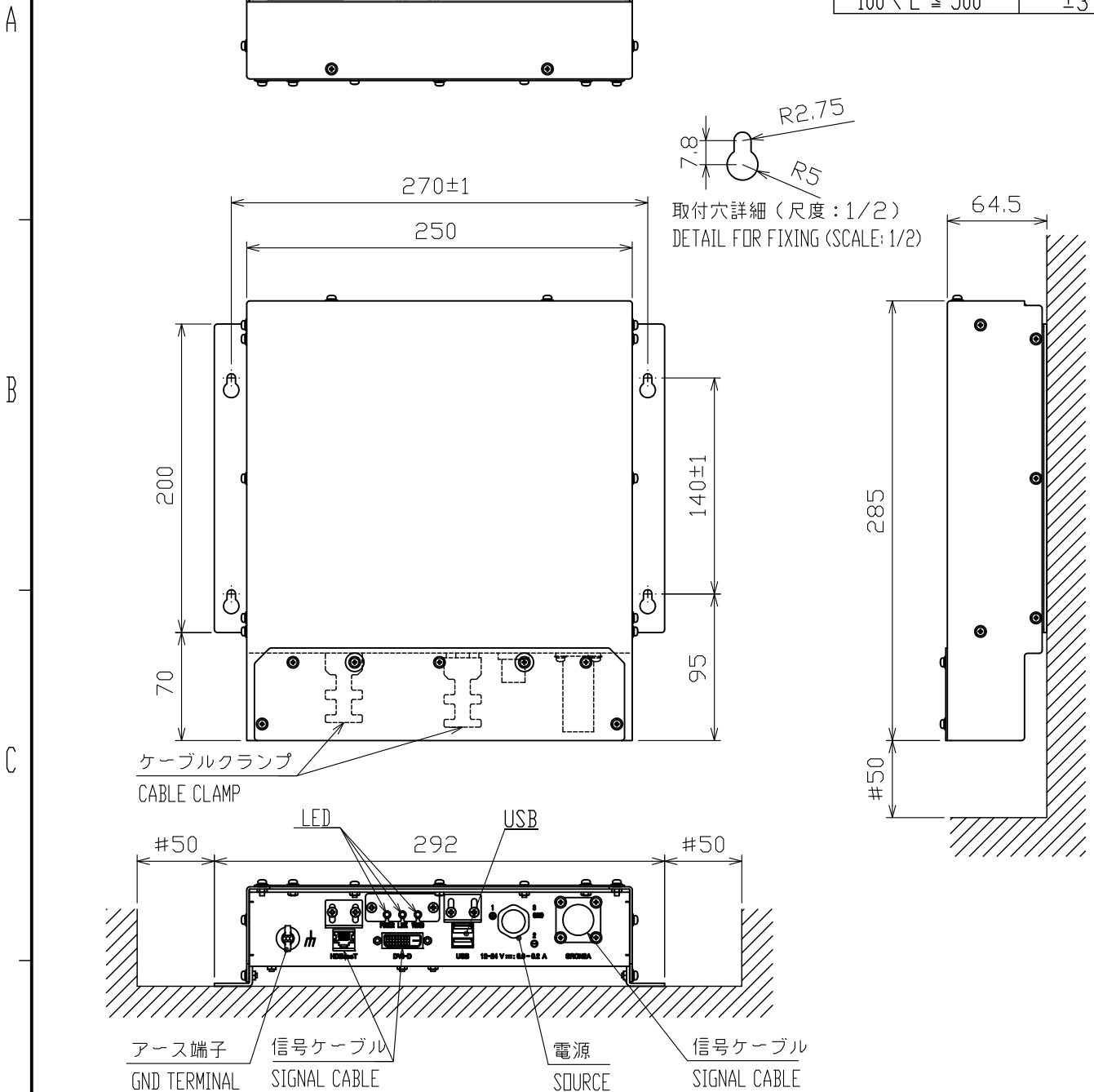

注記

1) 指定なき寸法公差は表1による。

NOTE

1. TABLE 1 INDICATES TOLERANCE OF DIMENSIONS WHICH IS NOT SPECIFIED.

DRAWN	9/Oct/2019 T.YAMASAKI		TITLE	TM000-FDX06 RX
CHECKED	9/Oct/2019 H.MAKI		名称	受信機 (壁掛・卓上装備)
APPROVED	9/Oct/2019 H.MAKI	FCV-T900 FAR-15x3		外寸図
SCALE	1/4	MASS 1.4 $\pm 10\%$ kg	NAME	RECEIVER UNIT (BULKHEAD/TABLETOP MOUNT)
DWG. No.	C3638-G04-A	REF. No.	PTM000-FDX06A-13	OUTLINE DRAWING



表1 (Table1)

寸法区分 (mm) Dimension	公差 (mm) Tolerance
$L \leq 50$	± 1.5
$50 < L \leq 100$	± 2.5
$100 < L \leq 500$	± 3
$500 < L \leq 1000$	± 4

15	六角ナット HEX NUT	SUS316L	14	M12		
14	バネ座金 SPRING WASHER	SUS316L	7	M12		
13	平座金 WASHER	SUS316L	7	M12		
12	平座金 WASHER	POM	7	T-201-11		
11	ステンレスバンド ROSE CLAMP	SUS	2	450-SUS		
10	御面スポンジ CUSHION RUBBER	SILICONE SPONGE	2	02-153-4322		
9	六角ナット HEX NUT	SUS316L	16	M12		
8	金属ワッシャー WASHER	SUS304	8	02-153-4325		
7	積層防振ワッシャー MULTI-PLATE WASHER 70	SUS304/CR	8	02-153-4323		
6	積層防振ワッシャー MULTI-PLATE WASHER 50	SUS304/CR	8	02-153-4324		
5	スペーサ (2) SPACER	SGP	7	02-153-4321		
4	押え板2 FIXING PLATE 2	SS400/CR	1	02-153-4317		
3	T Dワッシャー TRANSUDER ATTACHMENT	SS400/CR	1	02-153-4315		
2	船底板 HULL PLATE	SS400/CR	1	02-153-4311		
1	送受装置 TRANSUDER		1	CV-303		

品番 ITEM	品名 NAME	材質 MATERIAL	数量 QTY	図番 DWG.NO.	備考 REMARKS
	TITLE	T-625-A			
	名番	分割船底板キット			
	NAME	外寸図			
		TRANSUDER FIXING PLATE KIT			
	REF.No.	02-153-4310-0			
	DWG.No.	C2373-G08-A			

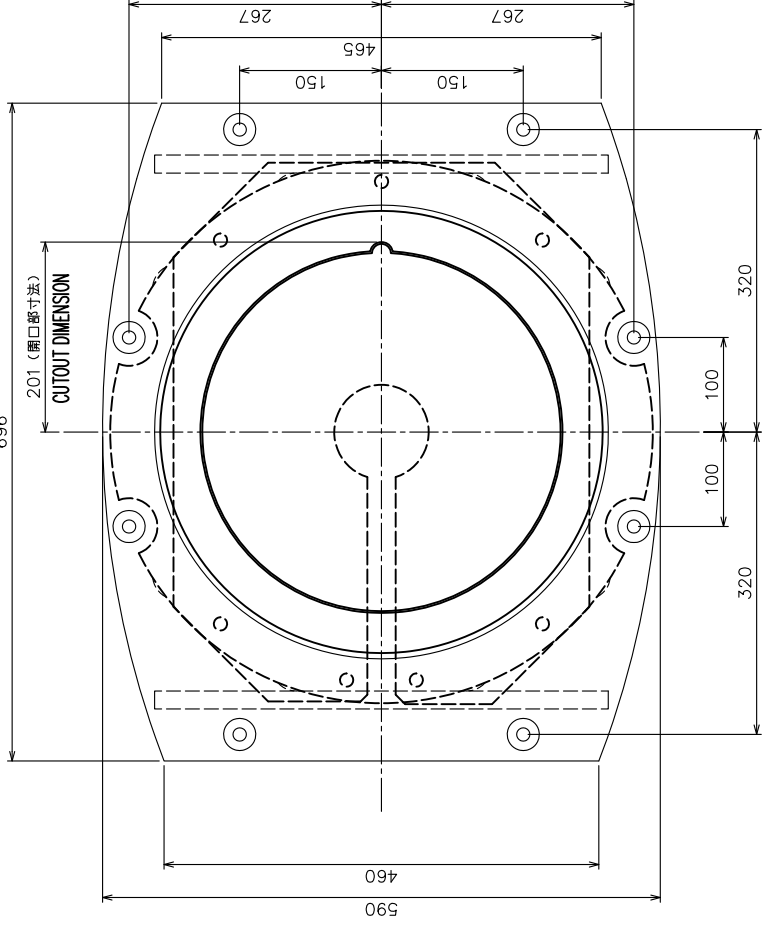
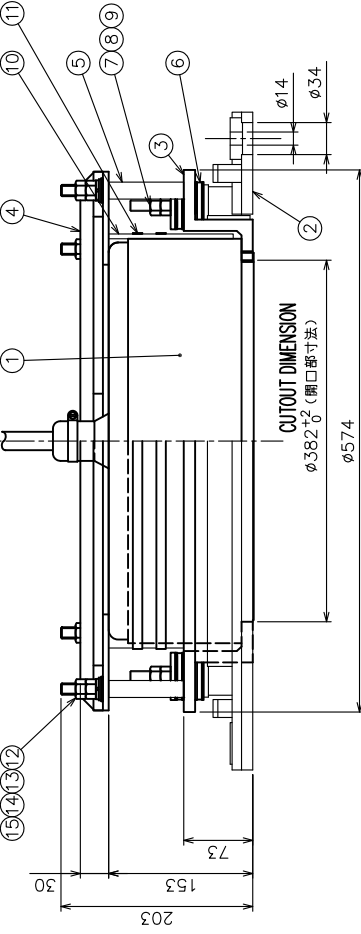
DRAWN 9/Mar/2010 I.YAMASAKI
 CHECKED 9/Mar/2010 I.TAKAHASHI
 APPROVED 11/Mar/2010 Y.NISHIYAMA
 SCALE 1/8 MASS 92 ±0.04
 DWG.No. C2373-G08-A

注記

1) 指定なき寸法公差は表1による。
 NOTE
 1. TABLE 1 INDICATES TOLERANCE OF DIMENSIONS WHICH IS NOT SPECIFIED.

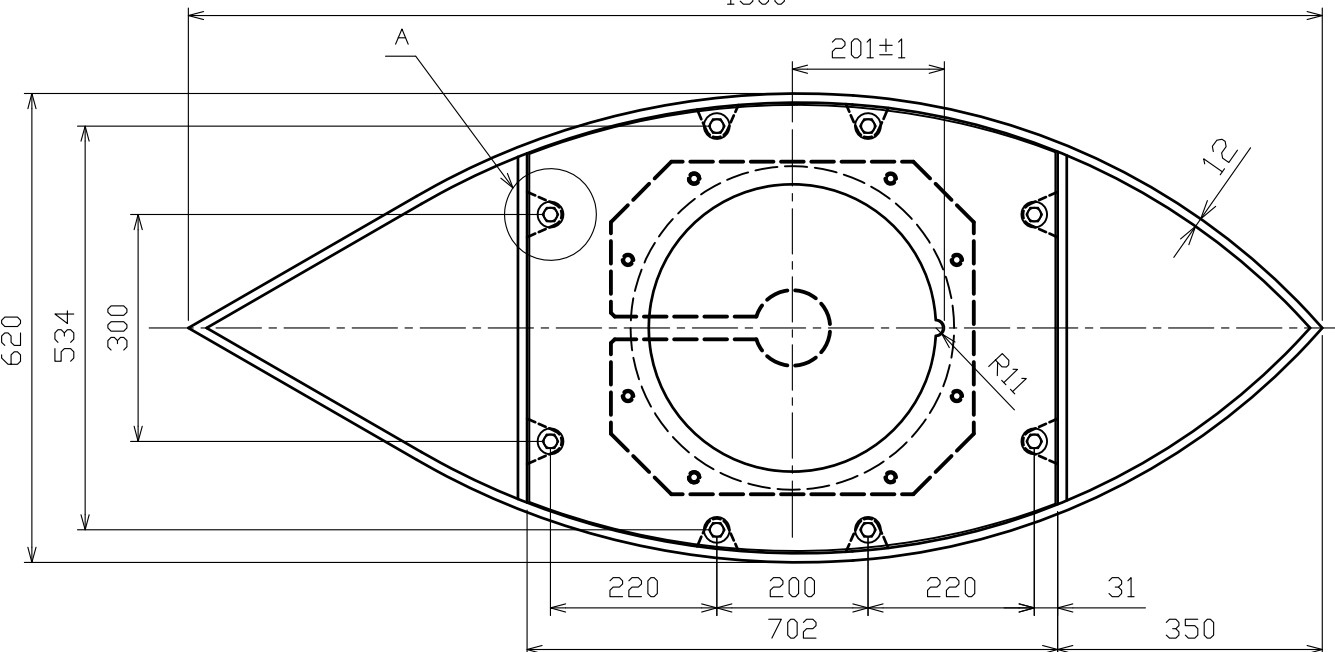
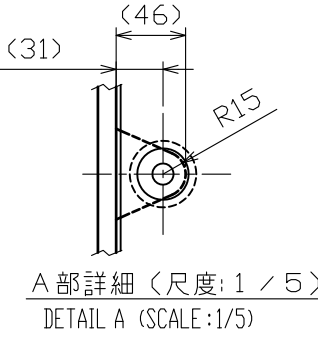
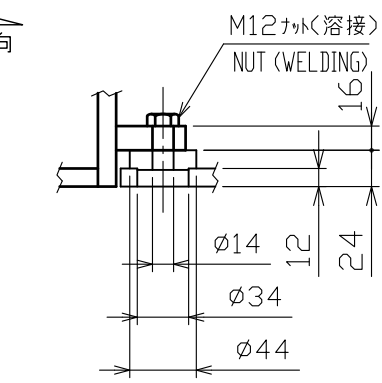
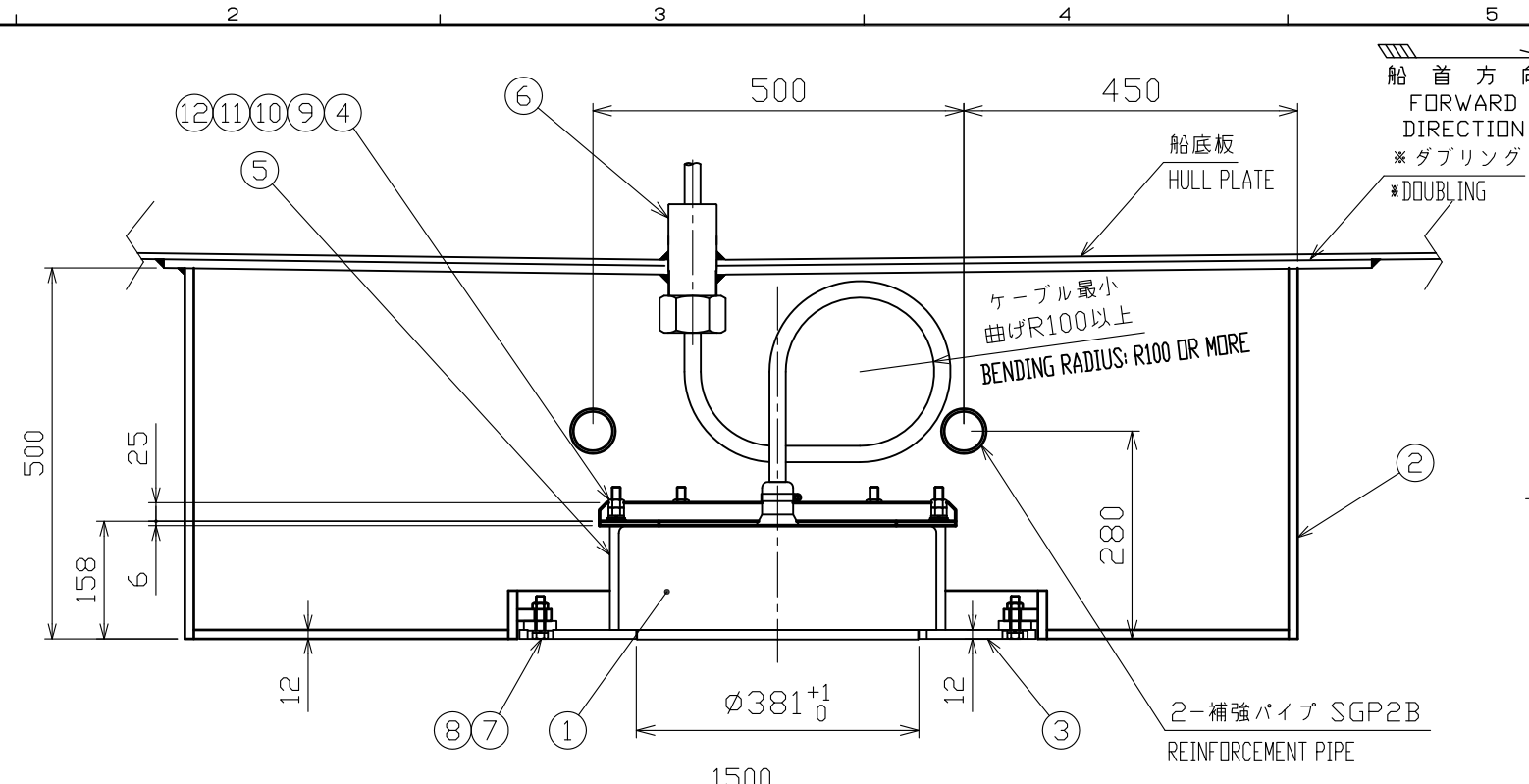

装備法分類番号 INSTALLATION METHOD	D-14
周波数 FREQUENCY	/ kHz

表1 (Table1)

寸法区分 (mm) Dimension	公差 (mm) Tolerance
L ≤ 50	±1.5
50 < L ≤ 100	±2.5
100 < L ≤ 500	±3
500 < L ≤ 1000	±4
1000 < L ≤ 2000	±5

要目表 PRINCIPAL ITEMS	
位置 POSITION	船首から FROM BOW
位置 POSITION	キールから FROM KEEL
突出量H PROJECTION	mm
取付状態 FIXING CONDITION	走行時水平 HORIZONTAL AT RUNNING
保護タンク PROTECTION TANK	

表2 送受波器の新旧コードと対応パッキン
TABLE 2 TRANSDUCER VERSION AND SUITABLE GASKET

送受波器 TRANSDUCER	部品コード CODE NUMBER	ケーブル径 CABLE DIAMETER	パッキン GASKET	部品コード CODE NUMBER
CV-303	00001253800	φ19.4±1.1	グラウンドパッキン GLAND GASKET	10032479010
CV-303*RoHS*	00003764500	φ22±1	グラウンドパッキンB GLAND GASKET B	10043323010

品番 ITEM	品名 NAME	材質 MATERIAL	数量 QTY	図番 DWG. NO.	摘要 REMARKS
12	平座金 FLAT WASHER	PDM	8	T-201-11	
11	平座金 FLAT WASHER	SUS316L	8	M12	
10	バネ座金 SPRING WASHER	SUS316L	8	M12	
9	六角ナット HEX.NUT	SUS316L	16	M12	
8	バネ座金 SPRING WASHER	SUS316L	8	M12	
7	六角ボルト HEX.BOLT	SUS316L	8	M12X50	
6	電線貫通金物 THRU-HULL PIPE		1	TFB-1600	
5	スペーサ SPACER	SGP	8	02-153-4303	
4	押え板 FIXING PLATE	SS400	1	02-153-4302	
3	送受波器取付フランジ FIXING FLANGE	SS400	1	02-153-4301	
2	タンク本体 CASING	SS400	1	02-080-2001	
1	送受波器 TRANSDUCER		1	CV-303	

注記

- *: 造船所手配
- 切断・溶接の際は、歪み防止のため送受波器を取り外した状態の“送受波器取付フランジ”を必ず取り付けておいてください。
- 電線貫通金物を溶接する際は、パッキンを取外して行ってください。
- 送受波器ケース取付の際には船首、船尾の確認をしてください。
- 船尾側上端に空気抜き用穴(φ10~φ20程度)をあけてください。
- 電線貫通金物はフレーム等の邪魔にならない所で送受波器に当たらずキャップナットが容易に締め付けられる位置に取付けてください。
- 網除け、保護タンクは必要に応じて造船所にて製作してください。
- 装備後はサビ止め塗装をはがした後、正規の塗装を行ってください。
- 塗装の際、送受波器面を塗装しないように注意してください。
- 送受波器取付け後、A部の隙間をシリコン等で埋めてください。
- 指定外の寸法公差は、表1のとおりです。
- ボルト類には焼き付き防止グリス(モリシーラ1910等)を塗布してください。
- 表記質量に送受波器の質量は、含まれていません。
- 送受波器ケーブルの最小曲げRは100以上とする。

NOTE

- *: SHIPYARD SUPPLY
- TO AVOID DISTORTION BY HEAT, PUT "FIXING FLANGE" (WITHOUT TRANSDUCER) ONTO CASING WHILE CUTTING AND/OR WELDING.
- REMOVE GASKET FROM THRU-HULL PIPE BEFORE WELDING.
- CASING SHOULD FACE BOW DIRECTION.
- MAKE A HOLE OF 10 TO 20MM IN DIA ON STERN SIDE TO ALLOW AIR TO ESCAPE FROM TANK.
- KEEP SUFFICIENT CLEARANCE AROUND THRU-HULL PIPE FOR EASY TIGHTENING AND SERVICING.
- IF NECESSARY, PROVIDE NET PROTECTOR AND PROTECTION TANK BY SHIPYARD.
- AFTER INSTALLATION, REMOVE ANTICORROSIVE PAINT FROM CASING AND THEN PAINT ACCORDING TO SHIPYARD INSTRUCTIONS.
- DO NOT PAINT TRANSDUCER FACE.
- FILL THE GAP "A" AROUND BOLTS' HEAD WITH SILICON SEALANT.
- TABLE 1 INDICATES TOLERANCE OF DIMENSIONS WHICH IS NOT SPECIFIED.
- APPLY BURNPREVENTION GREASE TO THREAD OF BOLTS.
- MASS DOES NOT INCLUDE TRANSDUCER.
- TRANSDUCER CABLE BENDING RADIUS: 100 mm OR MORE.

DRAWN	14/Apr/2020 T.YAMASAKI	TITLE	T-625
CHECKED	14/Apr/2020 H.MAKI	名称	送受波器タンク
APPROVED	15/Apr/2020 H.MAKI	FCV-30/38	送受波器装備図
SCALE	1/10 MASS ±10% kg	NAME	TRANSDUCER TANK
DWG. No.	C2373-T01-E	REF. No.	02-153-4300-5
		TRANSDUCER INSTALLATION	

2 3 4 5 6

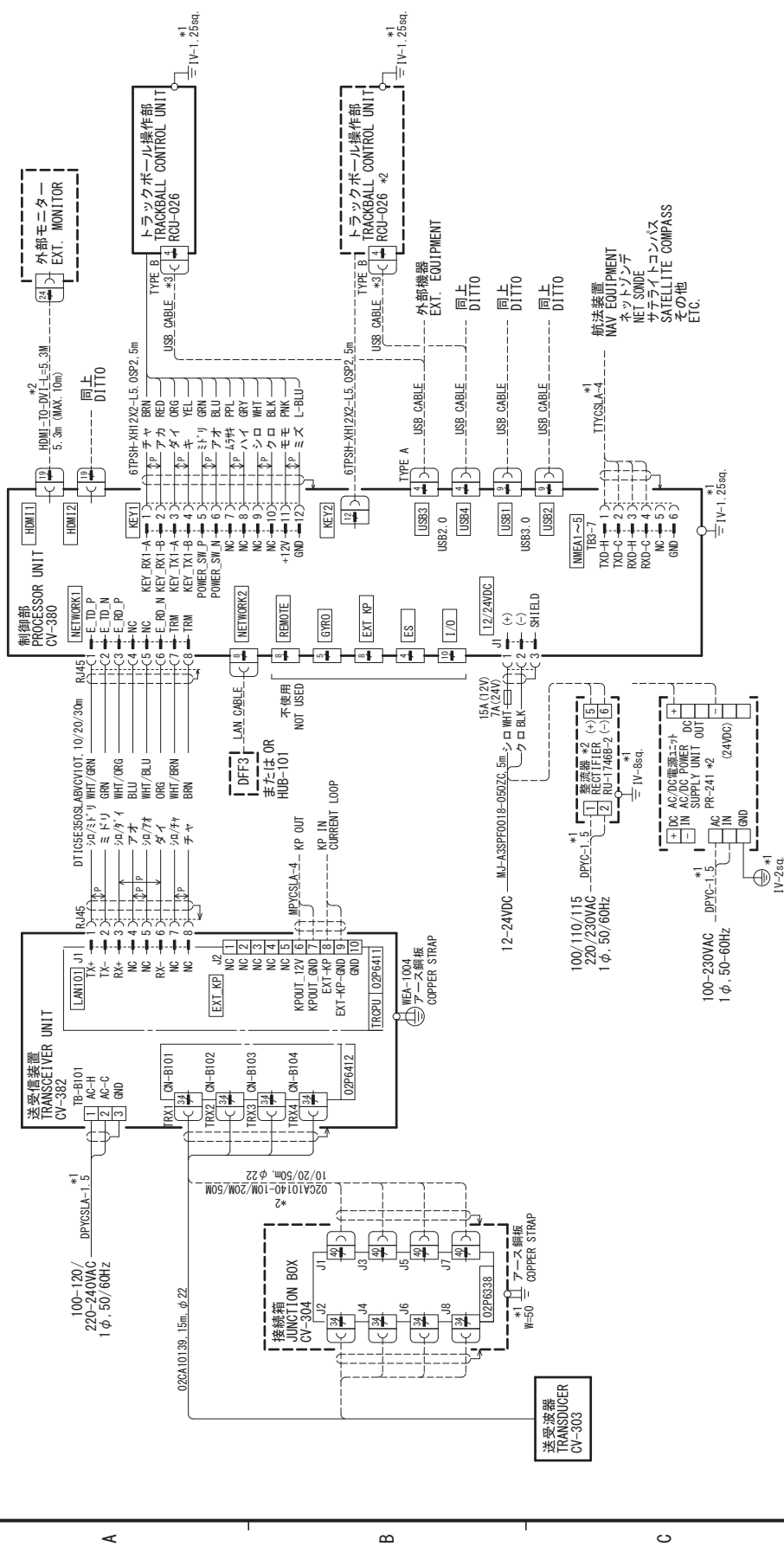

注記
 * 1) 造船所手配。
 * 2) オプション。
 * 3) 操作部上のUSBポートを使用するとき。
NOTE
 * 1: SHIPYARD SUPPLY.
 * 2: OPTION.
 * 3: TO USE THE USB PORT ON CONTROL UNIT.

DRAWN	12/Aug/2020	T. YAMASAKI	TITLE	FOV-38
CHECKED	12/Aug/2020	H. MAKI	名称	魚群探知機
APPROVED	19/Aug/2020	H. MAKI	相互結線図	
SCALE		1/MASS	NAME	FISH FINDER
DWG No.	C2392-001-C	REV.	REF. No.	02-177-2001-1
				INTERCONNECTION DIAGRAM

4

3

2

1

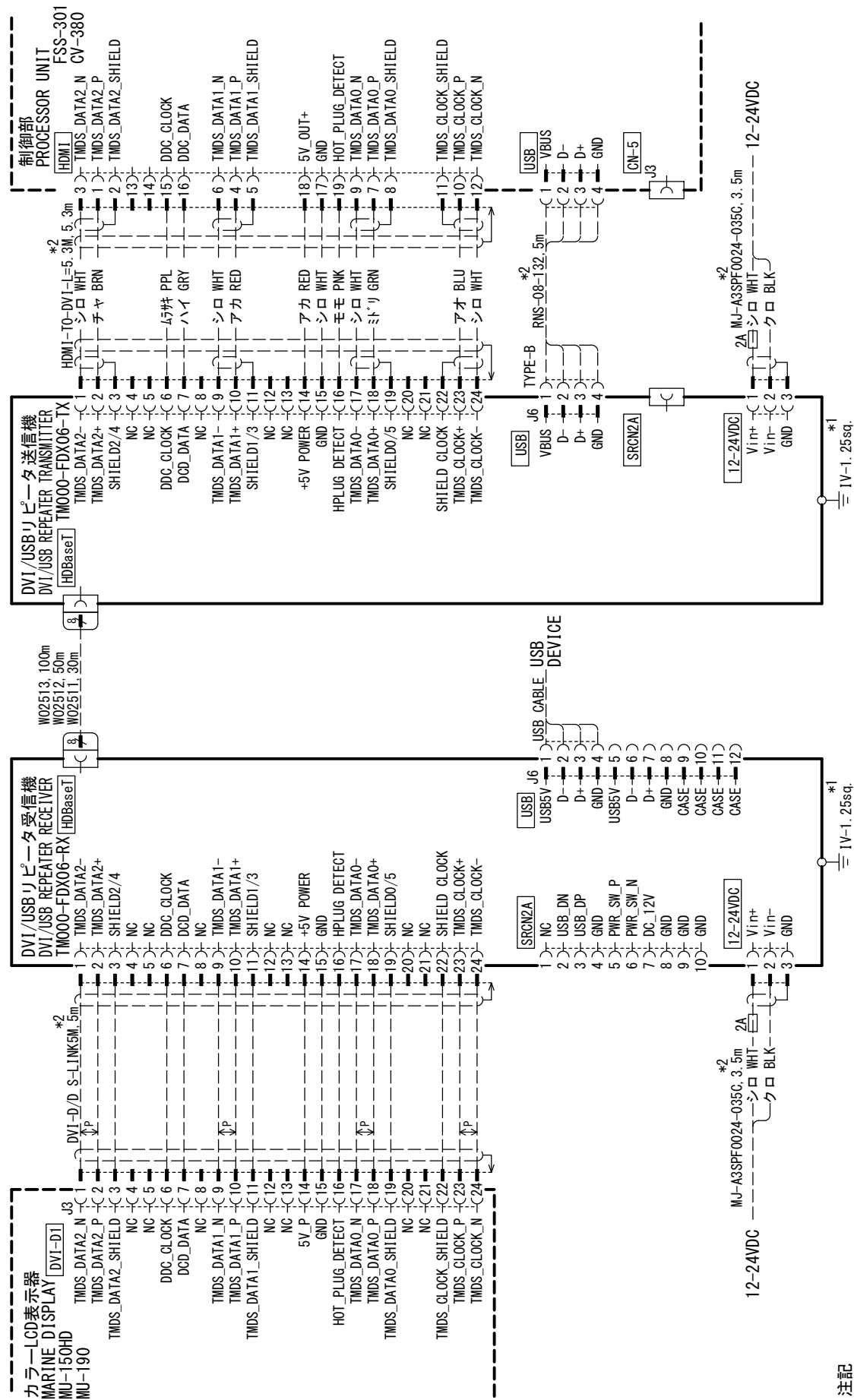

A

B

C

注記
 * 1) 造船所手配。
 * 2) オプション。

NOTE
 *1: SHIPYARD SUPPLY.
 *2: OPTION.

DRAWN	18/Feb/2020	T. YAMASAKI	TITLE	TM000-FDX06-TX/RX
CHECKED	18/Feb/2020	H. MAKI	名称	DVI/USBリピータ
APPROVED	18/Mar/2020	H. MAKI	相互接続図	
SCALE		1/25	NAME	DVI/USB REPEATER
DWG No.		C2393-002-A	REF. No.	INTERCONNECTION DIAGRAM